

Notice! The information contained in this document is for reference and information only.  
The pilot is the final and only responsible party for the safe operation of this aircraft.

# TL - ULTRALIGHT

Letiště 515, Pouchov  
503 41 Hradec Králové  
tel/fax 049 5213378  
tel +42049 5218910  
tel +42049 5211753  
info@tl-ultralight.cz  
www.tl-ultralight.cz

## TL - 96 STAR

Flight and operational manual  
Published in December 2000



Serial number: 99 S 25

Registration nmr.:

Revision: 1/8.10.2018

Notice! The information contained in this document is for reference and information only.  
The pilot is the final and only responsible party for the safe operation of this aircraft.

<b>1.</b>	<b>General information</b>	<b>6</b>
1.1.	Important information	6
1.2.	Description of airplane	6
1.2.1.	Airframe	6
1.2.2.	Fuelsystem	7
1.2.3.	Propeller	7
1.2.4.	Engine	7
1.2.5.	Meaning of movement of control component units	8
1.2.6.	Basic technical data of the airplane	8
1.3.	Layout of the airplane	9
1.4.	Detecting the center of gravity position, allowed and measured values	10
1.4.1.	Weighting the airplane for the the headmost center of gravity	10
1.4.2.	Weighting the airplane for the backmost center of gravity	10
1.4.3.	Measured values of the center of gravity for the airplane TL-96 Star before test flying	11
<b>2.</b>	<b>Operating restrictions</b>	<b>11</b>
2.1.	Restriction of the speed of the flight and reparation of position fault of airspeed indicator	11
2.1.1.	Airspeed ind. data reparation regarding the position fault of Pitot tube	12
2.1.2.	Reparation table of real and indicated air-velocity	12
2.2.	Weights and loads	12
2.2.1.	Maximum and minimum weights	12
2.2.2.	Siting of the load	12
2.3.	Engine operating restrictions	13
2.4.	Propeller operating restrictions	13
2.4.	Fuel and lubricant oil	13
2.4.1.	Fuel Tank	14
2.4.2.	Consumption of the fuel	14
2.5.	Restriction of maneuver	15
2.5.1.	Allowed turns	15
2.5.2.	Flight multiples	15
2.6.	The crew	15
2.6.1.	Minimal and maximal weight of the crew	15
2.6.2.	Pilot qualification	16
2.6.3.	Pilot´s place on the plane, ageof the crew, application of seat belts	16
2.7.	Maximum flight height	17
2.8.	Meterologic condition restriction	17
2.9.	Carriage of baggage restriction	17
2.10.	Types of airport traffic	17
<b>3.</b>	<b>Emergency process</b>	<b>18</b>
3.1.	Misfire of the engine	18
3.1.1.	Misfire of the engine during the flight to the height 200m	18
3.1.2.	Misfire of the engine during the flight above the height 200m	18
3.2.	Fire on board of the plane	18
3.3.	Vibrations	18

Notice! The information contained in this document is for reference and information only.  
The pilot is the final and only responsible party for the safe operation of this aircraft.

3.4.	Undercarriage failure	19
3.4.1.	Main undercarriage failure	19
3.4.2.	Nose undercarriage failure	19
3.5.	Using the rescue system	19
<b>4.</b>	<b>Normal processes</b>	<b>20</b>
4.1.	Starting up the engine	20
4.2.	Engine test	20
4.3.	Important parts made before getting off	21
4.4.	Taxying	21
4.5.	Taking-off	22
4.5.1.	Maximum power of wind at time of taking off	22
4.6.	Tasks after reaching the flight level	22
4.7.	Flight at the flight level	22
4.8.	Descend	22
4.8.1.	Sideslid	23
4.9.	Landing	23
4.10.	Tasks after landing	23
4.11.	Pilotage in lateral wind	23
4.12.	Flight in turbulent atmosphere	24
4.13.	Standing up to the lane	24
<b>5.</b>	<b>Output</b>	<b>24</b>
5.1.	Conditions for output assessment	24
5.2.	Speeds	24
5.3.	Rate of climbs and height loss from the beginning of stalling	24
5.4.	Ceiling	25
5.5.	Gliding range	25
5.6.	Getting off length	25
5.7.	Landing length	25
5.8.	Flight persistency	25
5.9.	Flying range	26
<b>6.</b>	<b>Maintenance and operating the plane</b>	<b>27</b>
6.1.	Parking	27
6.2.	Anchoring the plane	27
6.3.	Manipulation with the plane	27
6.4.	Assembly and disassembly of the plane	27
6.4.1.	Disassembly of the plane	27
6.4.2.	Assembly of the plane	28
6.5.	Washing and cleaning the plane	28
6.6.	Before flight inspection	29
6.7.	Filling the fuel	30
<b>7.</b>	<b>Service life of the flight and maintenance periodicity</b>	<b>31</b>
7.1.	Service life of the plane and its parts	31
7.2.	Workaday maintenance	31

Notice! The information contained in this document is for reference and information only.  
The pilot is the final and only responsible party for the safe operation of this aircraft.

7.2.1.	Lubricant plan and lubricant preparation	32
7.2.2.	Blocking, raising and jogging along preparation	32
7.2.3.	Disassembly of front wheel	32
7.2.4.	Wheel disassembly of main undercarriage	33
7.2.5.	Mending the tyre	33
7.2.6.	Electrical system voltage	33
7.2.7.	Tolerance and setting up values	33
7.2.8.	Supporting and subordinate construction	33
7.2.9.	Special assembly, controlling and setting preparations	34
7.2.10.	Special tools	34
7.2.11.	Materials for small reparations	34
7.2.12.	Changing the fuel filter in the engine area	34
7.2.13.	Maintenance of airscrew SR 2000 xa	35
7.3.	Contract revision	35
7.4.	Periodical revision after every 50hours	35
7.5.	Periodical revision after every 100hours	35
7.6.	Periodical revision after every 200hours	35
7.7.	Periodical revision after every 300hours	35
7.8.	Jacking points on the plane	36
7.9.	List of labels and their placing	36
<b>8.</b>	<b>Airplane repairs</b>	<b>36</b>
8.1.	Repairs of connection screw	36
8.2.	Repairs of rivet joints	37
8.3.	Pilotage repairs	37
8.4.	Airframe repair	37
8.5.	Fuel system repairs	37
8.6.	Engine repairs	37
8.7.	Electroinstalment and appliance repairs	37
8.8.	Revision of electroinstalment	38
<b>9.</b>	<b>Engine Rotax 912/912S maintenance</b>	<b>38</b>
9.1.	Oil refill	38
9.2.	Sparking plugs	38
9.3.	Refregarating liquid	38
9.4.	Service life of the plane, revisions and inspection of the engine	39
9.5.	Service life of rubber parts of engine	40

Dear airplane owner,

Notice! The information contained in this document is for reference and information only.  
The pilot is the final and only responsible party for the safe operation of this aircraft.

I would like to compliment you on the purchase of the ultralight airplane TL-96 Star which is the result of many years of development of our company. This company belongs, in its category, to European top.

With its output, TL-96 Star is getting near the small sports airplanes category, but flying with TL-96 Star is much economical and its maintenance is also much easier.

I believe that the aircraft will operate for your enjoyment for very long time and it will satisfy you. Also this Flight and operating guidebook should help you. You can find operating and maintenance information in this guidebook. Inseparable part of this guidebook is instruction for using the engine, airscrew and respectively the saving system.

I wish you a lot of joy from flying with Your new aircraft TL- 96 Star.

In Hradec Králové July 27, 1999

Jiří Tlustý  
owner of TL-ULTRALIGHT

**TL Ultralight s.r.o.**  
Letiště 515, Pouchov  
503 41 Hradec Králové  
**tel/fax +420049 5213378**  
**tel +420495218910**  
**tel +420495211753**  
**info@tl-ultralight.cz**  
**www.tl-ultralight.cz**

Notice! The information contained in this document is for reference and information only.  
The pilot is the final and only responsible party for the safe operation of this aircraft.

## **1.General information**

In case that this guidebook reveals to the rule UL1, UL 2 or UL 3, it is only a calling off corresponding rule of Letecké amatérské asociace české republiky – Czech republic amateur flight association. This association is encharged by Úřad pro civilní letectví-Office for civil aviation.

### **1.1.Important information**

Every airplane holder, operational organization and pilot of the airplane TL-93 Star must acquaint with this guidebook at its full lenght. This phamlet consists of flying and maintenance part of this type of airplane. This phamlet must be on board of the plane within other documents at all flights.

Its inseparable parts are the operating instructions for engine, airscrew and respectively saving system.

This airplane is intended to sports and recreational purposes. Also for performing basic and continuative practice. It is certificated by technical guideline UL 2 and it is not allowed to make commercial flights with the exception of practice and the lease.

This guidebook is valid only if the changes send to the airplane holder TL-96 Star are put into effect. These changes are gradually paginated and they contain removable pages. Respective pages should be changed in the guidebook. If there is no page with such number, new page is subsumed due to the sort order.

### **ATTENTION**

**This airplane belongs to the sports and recreational category and is dateless to the approbation of Úřad pro civilní letectví v ČR-Office for civil aviation in Czech Republic. Operating this airplane at one own risk.**

## **1.2.Description of the airplane**

### **1.2.1. Airframe**

Ultralight airplane TL-96 Star is two-placed full composite low wing plane with flowing elevator.

The fuselage is laminated, in some places made into sandwich, with oval cross section shaped to achieve the propitious proportion among the rigidity, weigh and aerodynamic drag. There is integrated the fuel tank, seats and the base of the board in the fuselage.

The undercarriage has three wheels with hydraulic disk brakes. On main wheels they are draped on a laminated spring. The front wheel is maneuverable.

The brakes are foot-operated at pilot´s place, each wheel can be braked separately.

The wheel can be equipped with aerodynamic covers.

The cabin is arranged with seats next to each other, it is covered with large either clear or with darker toned cover, which provides an exceptional view. Locking of the cabin is lockable at three points. At head part impact ventilation is controlled from the place of pilot, it can also be equipped with side circled or scrollable windows.

Notice! The information contained in this document is for reference and information only.

The pilot is the final and only responsible party for the safe operation of this aircraft.

The pilotage of the airplane is duplicated, arranged classically. Flowing elevator is controlled by the rod, direction indicator by wires. Ailerons and lifting flaps are controlled by rods.

The wing is rectangle all composite with main and helpful longeron from glassy laminate, The dust-cover is sandwiched. Lifting flaps are made into two-positions.

Flowing elevator is also composite, it is supplied with aggravating tab, and through the tab is also provided longitudinal trim of the airplane. The conception of the flowing elevator contributes to the low aerodynamic drag of the airplane. Producer of the fuselage is the company TL Ultralight.

#### 1.2.2. Fuel system

The fuel system constitutes by the integrated composite fuel tank in the fuselage. It is fitted out with fuel meter, distribution, closing cock, filter and mechanical fuel pump. These all belong to the engine types 912 and 912s. At engine 914 Turbo the supply is ensured electrically.

The fuel tank is equipped with lockable lid placed on the front right side of the fuselage. The producer of the fuel system is also the company TL Ultralight.

#### 1.2.3. Propeller

It is possible to use stationary and adjustable propeller. The description of the propeller is provided with your airplane and is included in the instruction for assembly and maintenance of the propeller which is a part of the delivery.

#### 1.2.4. Engine

Most used engines are types Rotax 912, 912S and 914, which ensure the airplane excellent dynamic and flying properties. Engines Rotax 912, 912S and 914 are four-stroke four-cylinder engines the type boxer. The cylinder head is cooled by the refrigerating liquid and the cylinders are cooled down by air.

There is a reductor at the engine, the engine has two carburettors. Detail information are enclosed in the instruction for using the engine.

### **ATTENTION!**

**None of the enclosed engines are certificated as a flying engines. Even though maximum attention is paid during the procedure of the engine, misfire of the engine can occur at any time. The only pilot is responsible for the consequences. The obligation of the pilot which is written down in the rule UL1 is to fly at all conditions the way to be able to glide and land safely to preselected area in case of misfire of the engine.**

Notice! The information contained in this document is for reference and information only.

The pilot is the final and only responsible party for the safe operation of this aircraft.

### 1.2.5. Meaning of movement of control component units

#### Foot pilotage:

Pushing on the left foot pedal, the airplane turns to the left if on land or in the air, pushing on the right pedal it turns to right on land or in the air.

#### Manual control :

Snapping the control bat to the pilot's body, the proe and the airplane is rising, pushing away the control bar the airplane is sinking.

#### Braking:

Wheels of the main undercarriage are braking, the control is only from the left seat, pushing on the top part of the left pedal-left wheel is braking and pushing on the top right pedal-the right wheel is braking. Synchronous pressure on both top parts of pedal-both wheels of main undercarriage are braking.

#### Lifting flaps:

Compressing the button on the hand lever between the seats and snapping this bar up, we can rebuilt the lifting flaps to second extended position and pushing on this lever while compressing the button, we can shift them in.

#### Balance:

The balance lever at middle bracket in front position correspond to the balance 'heavy on head', back position corresponds to the position 'heavy on tale'. Middle position corresponds to the balance for traveling speed.

#### Gas lever:

The gas lever in front position corresponds to full gas and gas lever in back position corresponds to idling move.

### 1.2.6. Basic technical data of the airplane

Wing span	9.20m
Length	6.50m
Height	2.15m
Wing area	12.10m <sup>2</sup>
Main wheel-spacing	1.95m
Wheel base	1.65m
Atmospheric pressure in tyres	2.0kPa
Brakes	hydraulic disc brakes
Rebound of main undercarriage	tires, resilience of the legs of the undercarriage
Rebound of the front wheel	coil spring
Volume of the fuel tank	68litres
Weight of empty airplane	299kg



Notice! The information contained in this document is for reference and information only.  
The pilot is the final and only responsible party for the safe operation of this aircraft.

**1.3.Layout of the airplane**

There are all the drawn dimensions in the layout. 1.4. recalls to this layout.

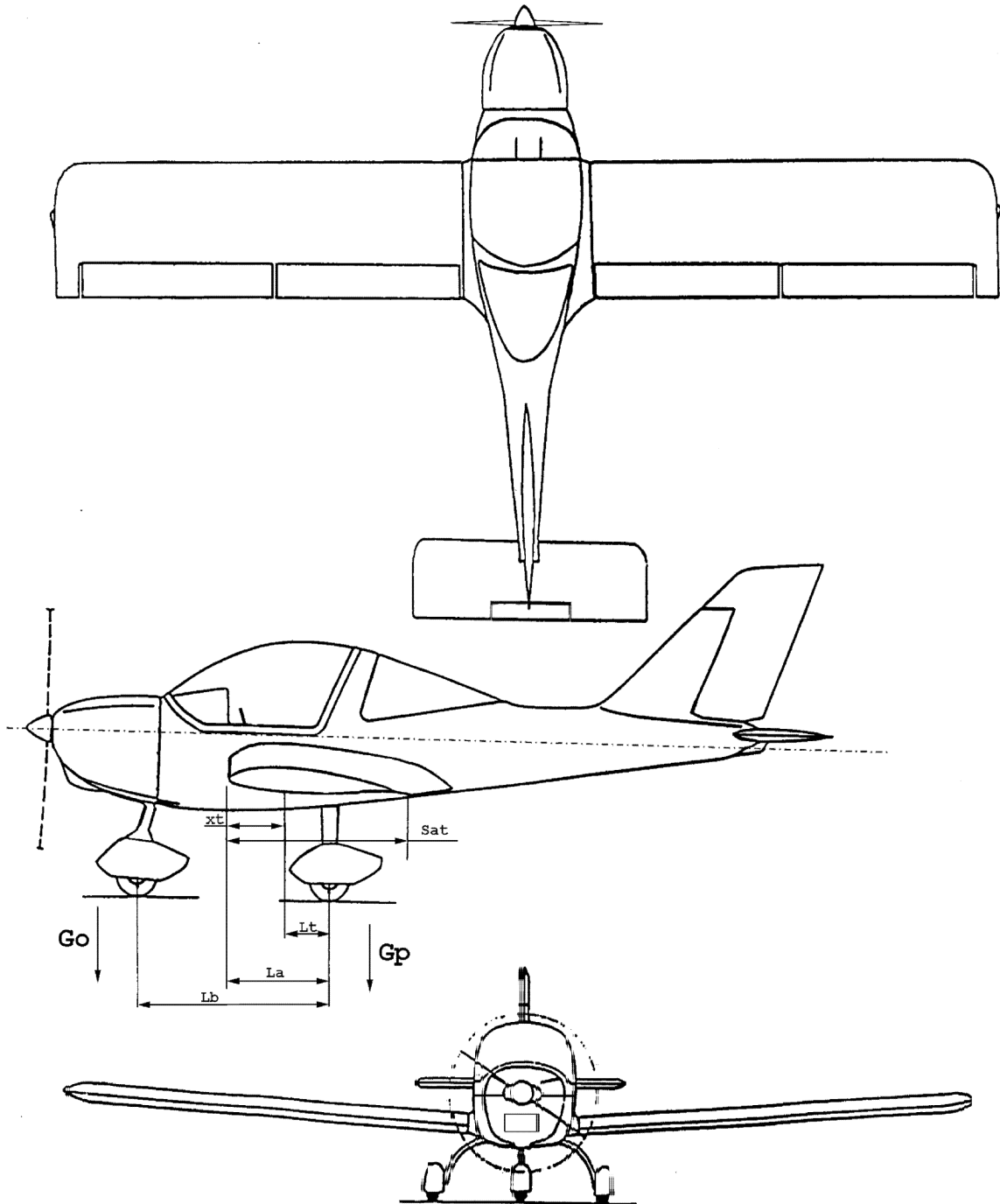

Notice! The information contained in this document is for reference and information only.  
The pilot is the final and only responsible party for the safe operation of this aircraft.

#### **1.4.Detecting the center of gravity position, allowed and measured values**

Observance of the center of gravity is decisive for the stability and manageability of the airplane. That's why it is necessary for every airplane holder to know how to diagnose the center gravity position of the airplane for factual occupancy.

It is necessary to know the length of the middle aerodynamic substance when making the calculation of the center of gravity. Calculated center of gravity must be inside the range given by the producer.

<b>Length of middle aerodynamic substance of the wing</b>	<b>1420mm</b>
<b>Allowed range of the center of gravity in %SAT</b>	<b>22-28</b>

When detecting the point of balance and subsequent calculation let the airplane stand in flying position at three weighting-machines and proceed after these instructions:

##### 1.4.1.Weighing the airplane for the headmost center of gravity position

- pilot's seat is occupied with a pilot with the lowest allowed weight
- there can not be any load on the plane, the fuel tank must be empty
- at the weighing-machines under the main undercarriage deduct the data of the weighing-machines, the weight effecting to the main wheels  $G_p$  you can find out as the sum of the data of both weighing-machines
- deduct the weight effecting the front wheel  $G_o$  at the weighing machine under the front wheel
- total weight of the airplane  $G_{vzl}$  is equal to the sum of  $G_p+G_o$
- measure the distance of axle of the main undercarriage from the axle of the front wheel  $L_b$  in millimeters
- measure the distance of leading edge of the wing / with plummet/ from the axle of the main undercarriage  $L_a$  in millimeters
- measure the vertical distance of the point of balance from the axle of main undercarriage  $L_t$  by the formula :  $L_t=G_o*L_b/G_{vzl}$
- measure the distance of the point of balance from the leading edge of the wing  $X_t$  by the formula:  $X_t=L_a-L_t$
- calculate the front center of gravity in percents by the formula  $X\%=X_t/SAT*100$

##### 1.4.2.Weighing the airplane for the aft center of gravity

Pilot's seat and the seat next to the pilot must be occupied with maximum weight of the crew, also the fuel tank must be full and the useful load must have the maximum weight. The procedure of measuring and weighing is the same as detecting the front center of gravity

Notice! The information contained in this document is for reference and information only.  
The pilot is the final and only responsible party for the safe operation of this aircraft.

#### 1.4.3. Measured values of the center of gravity for the airplane TL-96 Star before test flying

Serial number: 00S52

Measured value	Unit	Front center of gravity	Back center of gravity
Gp	kg	295	368
Go	kg	73	82
Gvzl	kg	365	450
Lb	mm	1710	1710
Lt	mm	344	315
La	mm	670	670
Xt	mm	326	355
X%	%	23	25

Detected position of the point of balance is 23-25%SAT for the front center of gravity with the pilot weighting 70kg, for the back center of gravity with the crew weighting 149kg.

## 2. Operating restrictions

### 2.1. Restriction of the speed of the flight and reparation of position fault of air-speed recorder

Presented speeds of the flight applies to the maximum take off weight of 450kg and at the conditions of the sea level by the MSA. The speed are presented in kilometers per hour.

Take off speed	75
Climb speed	130
Cruising speed	180-220
Accession landing speed	120
The speed of bearing the surface	62
Maximum speed of horizontal flight	230
Never never-exceed speed Vne	275
Maximum speed at turbulence	180
Stalling speed with no flaps	72
Stalling speed with flaps 35degrees / 2 <sup>nd</sup> grade flap /	62
Maximum speed for extending the 1st grade flaps Vfe	140
Maximum speed for extending the 2nd grade flaps Vfe	120

Vne is the never-exceed speed which the airplane can not fly

Vfe is the maximum speed for extending the lifting flaps, there are the same speed restrictions for the flight with extended flaps as for their extension.

Notice! The information contained in this document is for reference and information only.  
The pilot is the final and only responsible party for the safe operation of this aircraft.

2.1.1. Airspeed indicator data reparation regarding the position fault of Pitot tube

Harming the by –passing in the area of placing the Pitot tube can run short that the speed data indicated by the airspeed indicator do not correspond at all speed to the real aerial speed.

That’s why we do introduce the reparation of the indicated values for couple of the speed ranges. The real speed is at about 6.3% - 8.2% lower than the speed indicated by the board air-speed recorder. At low speed the relative mistake is lower and at higher speed the mistake is increasing.

For security reasons / not extending the maximum allowed speeds /we choose the type of lower real / calibrated / speed than the indicated speed.

All speed limits introduced in this guidebook as operating restrictions are initiated as the speeds indicated by the air-speed recorder. There is no need for any recount in the way of functioning of the airplane.

2.1.2. Reparation table of real and indicated air-velocity /km/h /

<u>Indicated</u>	<u>Actual</u>	<u>Indicated</u>	<u>Actual</u>	<u>Indicated</u>	<u>Actual</u>
60	58	110	103	160	148
70	67	120	112	170	157
80	76	130	121	180	167
90	85	140	130	190	176
100	94	150	139		

**2.2. .Weights and loads**

2.2.1. Maximum and minimum weights

- Maximum taking off weight 450kg
- Maximum landing weight 450kg
- Maximum weight of the fuel 49kg
- Maximum load of one seat 90kg
- Maximum weight of load behind the seats 4kg
- Maximum weight of the crew 70kg
- Empty airplane and detected position of the point of balance see point 1.4.3.

2.2.2.Sitting of the load

see point 2.10.

Notice! The information contained in this document is for reference and information only.  
The pilot is the final and only responsible party for the safe operation of this aircraft.

### 2.3.Engine operating restrictions

#### **ATTENTION!**

**Engines Rotax are not certificated as flying engines and sudden misfire can occur at any time, which can lead to emergency landing. Never fly with this engine at conditions when safe landing without using the engine is possible. There is no life service or safety certificate initiated to this engine. Also it does not correspond to any aerial standards.**

**All risks and the responsibility with using and operating this engine of this airplane are on the side of the user. We inform you, as the user, with the possibility of sudden misfire of the engine.**

Engine restrictions for engines Rotax 912 and 914, for the 912S are the same values as for engine 912.

Minimum temperature of air when taking off in Celsius	-25
maximum temperature of air when taking off	+50
Maximum engine revolutions 1/min	5.800
Maximum steady revolutions 1/min	5.500
Maximum time of running the engine at maximum revolutions	5 minutes
No-load speed	1.400

This data can slightly differ at factual conduct of the engine, for details look at the Instruction for using the engine. These data introduced in these instruction are main.

### 2.3. Propeller operating restrictions

There is a general requirement for protecting the propeller against all winds effects for all types of delivered propeller. Covers for your airscrew blades were delivered together with your airscrew and please, use them at anytime when your airplane stands off.

At any damage which can exhibit by increased jitter, it is necessary to discontinue the flight and make the reparation by the producer's instructions.

There is a technical description and principle of maintenance of the airscrew which you should go through. Delivered propeller was chosen due to the delivered engine the way not to limit the engine speed at allowed modes of functioning the airplane.

The propeller is subject to regular revision at the producer, its periodicity usually goes beyond the guarantee period of the airplane as an integrate. Behave the way the instruction to the airscrew profess.

### 2.4. Fuel and lubricant oil

For engine Rotax 912,912S and 914 there are many approved fuel types. Details are enclosed in the instruction for maintenance for the engine. In our conditions we recommend using the petrol Natural 95. Peruse the demands for the fuel prescribed by the producer in detail. In emergency to know what other fuel is possible to use.

There are also conditions prescribed by the producer for the oil used in the engine and these conditions are also enclosed in the instruction for maintenance for the engine. In our normal conditions we recommend the oil Castrol GTX 3. There are types of oil with which can the term for change of the oil and oil filter shorten from 100 to 50 flight hours. These details are in the instructions of maintenance for the engine.

Notice! The information contained in this document is for reference and information only.

The pilot is the final and only responsible party for the safe operation of this aircraft.

#### 2.4.1. Fuel tank capacity

Total volume of tanks	68litres
Unexhaustible supply	3litres
Minimum amount of fuel when taking off	8 litres

Unexhaustible amount of fuel is such amount of fuel in the tank in which can occur first symptoms of the lack of the fuel at normal conditions.

#### 2.4.2. Consumption of fuel

The consumption of fuel expressively depends on the type of used airscrew, engine, for factual airscrew and engine then on the technique of pilotage, total weight of the airplane, height of the flight, flight regime and the consumption is expressively influenced by the meteorological conditions / the consumption is increasing with higher temperature /. In general, flight with heavier airplane requires higher engine output because for reaching needed rising force it needs to be progressed with bigger angle of incidence, so the aerodynamic resistance is higher. Aerodynamic resistance is also increasing with second power of the speed of the flight and that's why the consumption of the fuel is increasing with higher speed. The consumption-output of engine curve is enclosed in the instruction for maintenance for the engine. Also used airscrew expressively influences the consumption. Positioning the angle of incidence of the airscrew blades can be a compromise among many various flight regimes at stationary or adjustable airscrews. Using adjustable airscrew can the consumption decrease by 10-15%.

The average consumption for steady running flight with the speed of 170km/per using the engine Rotax 912 or 914 and using the on land adjustable 3blade airscrew at the weight of the airplane 450kg.

With using the fuel computer, which also evaluates the immediate hour consumption of the fuel, you can, for factual conditions, optimize flight regime and achieve that way another reduction of the consumption.

Remark: In this context it is much more interesting for traveling the consumption of fuel per hour, the consumption of fuel to indicated 100km of flight, so the portion of the fuel in liters and indicated aerial speed in hundreds of kilometers.

Whilst consumption of the fuel for an hour of flight enables us to find out how long you can keep in the air, the consumption of the fuel for 100kilometres tells us what indicated aerial distance the airplane can fly. The flight at minimum consumption for 100km represents the most valuable way of flight for actual trace. You will find out later, that the consumption of 17litres for 1 hour at the speed of 195km/h is more valuable than seemingly low consumption of 12 liters per hour at the speed of 120km/h.

Notice! The information contained in this document is for reference and information only.  
The pilot is the final and only responsible party for the safe operation of this aircraft.

**2.5.Restriction of maneuver**

The restriction of the airplane UL in the view of allowed maneuvers is determined by the requirements of the rule UL2 part 2. which allows for this category only **non-acrobatic operating**, there are also technical restrictions of the airplane on its own. Non-acrobatic operation due to UL2, part 1., letter A, point 2 includes any turns needed for normal flying, practicing of drops and sharp turn to 60degrees. We also overplay that the airplane TL 96 Star with its exceptional attributes leads on operating acrobaticism, this airplane is not an acrobatical airplane and intentional drops, spins and acrobaticism are strictly prohibited.

2.5.1. Allowed turns

- non-acrobatic operations in sense of definitions proposed at the top by the rule UL2
- sharp turns are not recommended at lower speed than 130km/h
- use maximum 1/3 of full displacement at the speed over 180km/h

2.5.2. Flight multiples

Flight multiple expresses the load of the airplane while operating with inertial and aerodynamic power in order to its total allowed maximum weight. Airplane TL 96 Star is certificated for maximum taking off weight of 450kg. Also the rule UL 2 demands the operating multiples

N1	+4.0
N2	+4.0
N3	-1.5
N4	-2.0

N1, N2, N3, N4 ..... operating multiples by the diagram V-a / turn envelope /

**2.6.The crew**

2.6.1. Minimum and maximum weight of the crew

TL Star is two placed and there **are three restriction conditions, which must be kept in the view of the weight.**

First is the minimum weight of the crew 70kg. This minimum weight ensures the observance of the center of gravity so its good controllability and the stability at the flight. If this condition is not fulfilled it is necessary to fasten respective amount of weight to another seat.

Notice! The information contained in this document is for reference and information only.  
The pilot is the final and only responsible party for the safe operation of this aircraft.

Second condition is not to overpass the maximum total weight of the airplane 450kg. The observance of this condition is for the airplane to have the attributes and be so safe as it has been approved. The weight of the airplane without the crew responds to the sum of its weight with no fuel and the weight of the fuel. There is a label in the cabin on left front side where maximum weight of the crew with various volume of the fuel in the trunk is presented. Third condition is maximum load of one seat with no more than 90kg. Remember, usually it is not a problem to take off with overpassing the maximum weight but it is exactly the problem of landing.

**ATTENTION**  
**Maximum weight of 450 kg can not be overpassed in any case!**

#### 2.6.2. Pilot's qualification

TL 96 Star is aerodynamically controlled airplane. The rule UL 1 in head 3 determines the requirements for qualification of the pilot for this category of airplane.

The requirements can change by time and that's why get to know the valid wording of this rule in time when this problem is up to date. In time of pressing this guidebook applies:

- pilot must have the qualification at least of " pilot of UL aerodynamic controlled"
- if instructor ULLa is on board, the pilot can have the qualification of learner ULLa
- piloting learner ULLa can be on board alone, when he is taken aback by the valid training program in such part, when he is able to operate independent flights
- to be able to have another person on board with no qualification, it is necessary for the pilot to have flown at least 50 flight hours on ULL and from this at least 5 flying hours at the type TL 96 Star

#### 2.6.3. Pilot's place on the plane, age of the crew, using the seat belts

The airplane TL 96 Star is equipped with two pilotages and the ability of seeing the appliances from both seats is well. Assessing the place of pilot is not a technical question but the law question. In this sense from the habit we determine the pilot's seat to the left side.

The age of the pilot is not confined in any way and is derived of the requirements of the minimum age of the pilot or piloting learner by the rule UL3. The upper limit of the age is given by the health capability, so the holding of the valid piloting license.

The age of the other person is not determined by any rule LAA, but in the way of minimum age we can generally consider that the second person of the crew should have the size to be able to use the seat belts.

On basis of this general requirement with reference to the rule UL1, head 3, article 3.3., it is necessary in factual case for the pilot to decide if he will accept factual person on board, taking account on the age, physical and mental ability.

As producers we can not give any recommendation nor any restriction. We lay stress on the crew to be using the seat belts which are fastened.



Notice! The information contained in this document is for reference and information only.

The pilot is the final and only responsible party for the safe operation of this aircraft.

### 2.7. Maximum flight height

From technical view the airplane is able to rise into such height, when it is permanently able to be rising with the speed of 0.5m/s at the speed of flight 130km/h / practical ceiling/. Factually this technical ability depends on actual weight of the airplane, conditions of engine, the airscrew output, meteorological conditions and etc.

In the way of legislative, the height of the flight is influenced by many restrictions which can change in course of time. Meantime, these restrictions are introduced for example in the rule UL1, head 2., point 2.7. make sure you get to know these conditions in its full length. We roughly introduce for orientation, these restrictive conditions:

-with ULLa it is possible to fly only at conditions VFR during the day, and only to the flight level f FL 205, it means 6.250m MSL

-within its borders of the height limit FL 205 it is necessary to respect the conditions laying the flight in single forms of the aerial area / flying schedule, radiolink, responder.../

### 2.8. Meteorologic condition restriction

Operating the airplane is restricted on meteorological conditions and also on constitution of valid rules for the performance of the flight /keeping the meteorological minimums and the rules of flights in single forms of the aerial area – see the rule LAA ČR UL1 /, also technical and flying attributes need to be considered. There are these restrictive conditions:

Maximum outside temperature	+45 degrees of Celsius
Minimum outside temperature	-15 degrees of Celsius
Maximum vertical side component of wind	3m/s
Maximum speed of the wind in the direction of taking off	1m/s

Operating restrictions of the airplane in the way of meteorological conditions in cooler weather are determinated mostly by the possibility of ice formation. Keep away from flight in conditions which increase the probability of its formation.

### 2.9. Carriage of baggage restriction

Transport of load is restricted by the valid rules and also by the technical possibility.

Valid flying rules prohibit the transport of some kinds of loads, for example weapons, explosives, volatile and caustic agents and etc.

In the way of technical possibility the airplane is able for transportation in its cabin only at these conditions:

-maximum weight of the airplane can not be overpassed

-the load can be transferred only if it does not influence controllability of the pilot, the movement and the view of the pilot in any way, also the load must be mounted to the seat

-small sized things can be conveyed in side pockets of padding

-at the put off area in the back under the overlap of the cabin behind the seats there can be conveyed only such things, when the center of gravity will be ensured. At the same time, the load must be kept the way not to terminate the pilot's view and controllability even in worse flying conditions / for example flying into the turbulence /

### 2.10. Types of airport traffic

Flying rule and the equipment of the airplane terminate the operating with the airplane only for flights under the conditions VFR during the day. Other flights are strictly prohibited.

Notice! The information contained in this document is for reference and information only.

The pilot is the final and only responsible party for the safe operation of this aircraft.

### **3. Emergency process**

#### **3.1. Misfire of the engine**

The procedure while failure of the engine differs due to the time we have to solve the situation, so the height of the flight where the failure occurs.

##### **3.1.1. Failure of the engine during the flight to the height 200m**

- bring the airplane to gliding
- at small height, perform the emergency landing in the direction of the flight because turning at small height above the land and with low speed can give upon the risk of fall into the spin
- at higher height perform other tasks that will increase the safety of emergency landing – which are
- close the fuel supply to the engine
- fasten your seat belts
- perform the emergency landing to free area with no barriers and if it is possible against the wind

##### **3.1.2. Failure of the engine during the flight above the height 200m**

Bigger height will enable you to find out the reason of the engine failure, perform these tasks:

- bring you airplane to gliding
- make sure, the ignition is on
- check the fuel status
- try to launch the engine

If the engine is not able to start up, proceed by the point 3.1.1.

#### **3.2. Fire on board of the plane**

In case of fire on board, proceed this way:

- close the fuel supply to the engine
- open to maximum the gas lever of engine for the fastest consumption of the fuel behind the shut-off the fuel
- perform the distress call
- after the failure of the engine, turn off the ignition, all electrical appliances and the main switch
- perform the emergency landing

#### **3.3. Vibrations**

Vibrations can occur due to flight in bad weather flight regime, or due to the technical fault on the airplane.

If unnatural vibrations occur, make sure you are not flying the speed close to the stalling speed or if you are not flying in glide.

The airplane signalize the vibrations in pilotaging the airplane with approaching stalling speed, this is the consequence of beginning breaking of the line of flow. In this case perform the change of flying regime / recall the practice of inhibition of the fall /.

Vibrations can exhibit by the glide performing and this is the consequence of unsymetric by-passing the aerodynamic clean airplane TL 96 Star. In this case slow down the speed of the glide.

Notice! The information contained in this document is for reference and information only.

The pilot is the final and only responsible party for the safe operation of this aircraft.

If you quickly exclude some of the sources of increasing vibration written at the top, proceed this way:

- try to find such regime of the engine when the vibrations are as low as possible
- if the vibrations are increasing, perform the emergency landing with turned off engine alternatively perform the safety landing

### **3.4.Undercarriage failure**

#### **3.4.1.Main undercarriage failure**

Land on the side of not damaged leg, on this side using the ailerons, try to relief the damaged leg as long as possible, in case of the main undercarriage failure.

#### **3.4.2.Nose gear undercarriage failure**

In the course of the proe undercarriage failure, try to keep the nose up as long as possible, if possible do not use brake, because the inertia force actuating on the center of gravity of the airplane is trying while braking to collaps the proe of the airplane down. Try to land on a appropriate area and if possible against the wind, to slow down the landing speed against the ground.

### **3.5.Using the rescue system**

If your airplane is equipped with the saving system, you have received with handed documentations ``Guidebook for assembling and using the saving system`` elaborated by the producer. Go through this guidebook in its full length and keep to the procedures which are introduced there.

The handgrip which activates the saving system is placed in the upper part of the back upper lap of the cabin between the seats.

Do not forget to unlock and lock off the saving system before the flight and to lock it after the flight.

Generally, the saving system is recommended to use in the case of definite loss of control under the airplane, for example for its destruction. In the case, perform:

- turn off the ignition
- fasten your seat belts
- activate the saving system
- if the airplane is equipped by the radio perform the distress call

When the airplane is dropping steadily, the airplane is in the position wheel down. It is necessary to count with a damage of the airplane when falling down to the ground.

### **ATTENTION!**

**The saving system is constructed for the maximum speed of flight 240km/h, so if such situation happens, which responds to using the saving system, arbitrate quickly.**

**Practice the movement of your hand activating the saving system and make sure, there are no barriers in activating-seat belts or clothing. Before the flight, introduce the placing of the starter to the fellow-traveller and let him try on a dustproof system if he is possible to use it.**

Notice! The information contained in this document is for reference and information only.  
The pilot is the final and only responsible party for the safe operation of this aircraft.

#### 4. Normal processes

##### 4.1. Starting up the engine

Tasks which need to be done especially before first startup of the engine in the flight day, or in the case the engine had cooled down, are written in detail in the guidebook for the maintenance for the engine of your airplane, which was delivered to you with other documents. When starting up the engine, please keep to the device included in that handbook. Here are included some of the principles.

-before starting up the engine, make sure all conditions for its safe starting up are kept / UL 1, point 3.8.6/

-at a cool engine, turn over the airscrew several times in its direction for the oil from the engine to be pushed in the tank

-if the airplane is equipped by adjustable airscrew, set it to the smallest angle of incidence

#### **ATTENTION**

**Always do this task only when the both circles of ignition and the main switch is off**

-open the fuel tap if is closed

-turn on the main switch

-turn on both ignition circuits

-at cool engine, pull out the saturator

-set the gas lever for no load, or 10% of the output

-proceed the starter in activity

- be starting up with no interruption for maximum 10sec.

If the engine is not started, let the starter cool down for about 2 minutes and then repeat the starting. Overheated starter loses its output very quickly and the engine is hard to start with it because it does not rev up to the sufficient amount engine revolutions.

##### 4.2. Engine test

The engine test is made when the engine is warmed up with the goal to verify its operating efficiency. The procedure for the warming up the engine and making the test of ignition is again introduced in its full length in the handbook for the engine, keep to the procedures enclosed there.

We initiate only the basic principles:

-let the engine run for about 2 minutes with the revolutions of 2000/minute and continue with its warming up with the revolutions of 2500/min till the oil temperature does not reach 50°Celsius. Check the temperatures and the pressures while warming up and if all operating values have been reached

-do the test of ignition at the revolutions of 4000/min, the drop of the revolutions for each circuit can not be higher than 300 revolutions per minute, the difference of the revolutions can not reach more than 120 revolutions per minute. If you find out that there is no drop of the revolutions, it can mean that interruption of the short circuit cable, which turns off the ignition circuit, has occurred. In this case try to turn off the engine. If the engine would not turn off after turning off both ignition circuits, stop the fuel supply to the engine and let the engine come down. Check the connection of the connectors of the ignition circuit / under the engine hood / .

Notice! The information contained in this document is for reference and information only.

The pilot is the final and only responsible party for the safe operation of this aircraft.

- set the revolutions to 5 000 per minute for the time of 30 sec
- 3times smoothly come from the no load to maximum revolutions –5 800 per minute
- set the no load
- if you have the adjustable airscrew, re-examine its functioning by reconstructing and set the airscrew to small angle of uprising

There can not occur any irregularity nor pendulums of the revolutions while the engine test. No allowed pressure and temperature values can be overpassed. **The gas lever should be set slowly and smoothly.**

#### 4.3.Important parts made before getting off

Do not underestimate the important parts before the start, make your own system in proceeding them. At the beginning it is convenient to write them down and proceed them by the list.

In the bottom, there is a list, the way you could proceed it from the upper part of the board desk to the bottom part / altitude meter, gas pressure indicator / to the middle konzola / opening and the fuel supply, setting up the airscrew, control of the pilotage, setting up the balance, seat belts / , to the sides / side cabin shut off/ and to the upper back / middle shut off of the cabin, saving system lock off/, the check up consists of these activities:

- while taxiing, try the function of the brakes and pilotage of the front wheel, maximum speed of taxiing is 4km/h / slow walk /
- set the altitude meter
- check the gas pressure indicator
- check if all required values of the engine are achieved
- check if both ignition circuits are turned on
- check the turning on of the appliances, respectively check the artificial horizon
- check the opening of the supply of the fuel
- check the amount of the fuel / see the minimum amount of fuel at taking off/
- check the setting up of the airscrew to the small angle of incidence / when the airscrew is adjustable
- check the free movement of the gas lever, pedals, balance and lifting flaps, check the reactions of the controlling agents to the movement of possessing principle, compensate for the 'slightly heavy on head ''
- check the cabin locking off

#### 4.4.Taxying

Maximum speed of taxiing is 4km/h. There is a very good view from the airplane while taxiing but be careful for barriers in front of the airplane and also on side, especially when you were used to upper wing plane.

Most assembled airscrews has a yellow paint coating on inside ends, which can be interrupting a bit because it makes an annular ring in field of view, but on the other side it supports the safety of taxiing because it defines the working area of the airscrew.

Small speed of taxiing can aggravate the ventilation of the cabin, in hot or sunny weather keep your circled side windows opened against the direction of taxiing, the ventilation will expressively get better.

Notice! The information contained in this document is for reference and information only.

The pilot is the final and only responsible party for the safe operation of this aircraft.

**In no case do not taxi with open cabin because while riding on unlevelled ground the cabin hang-up could be damaged**

#### 4.5. Taking-off

- lifting flaps should be set to 15 degrees
- release the brakes and smoothly add full gas, you should count with the efficient engine to increase the revolutions of the airscrew very quickly and its reaction moment and its oblique blasting action have the effort to change the straight direction to the left / at engine Rotax 912,914/
- at the speed of 50km/h, relief slowly the front wheel
- at the speed of 75-85km/h the airplane airbones, keep the straight direction of the flight by declutching of the right leg, hold underfoot and keep till the speed of 130km/h
- come smoothly to rising at the speed of 120km/h
- at the height of 50m, close the lifting flaps
- descend the revolutions at latest 5 minutes to at least steady allowed revolutions, if you need to rise more with the airplane rise in the regime of reaching the flight lever

##### 4.5.1. Maximum power of wind at time of taking off

Maximum wind speed when taking off is enclosed at the point 2.9. Meteorological restrictions

#### 4.6. Tasks after reaching the flight level

- trim the regime of the engine to travel regime
- in case of adjustable aircrew, set the airscrew to the angle of incidence convenient for the speed of the flight
- outweigh the airplane to horizontal flight
- check the engine values, functioning of the appliances and the regularity of the engine
- evolve the seat belts
- set the required values of heating and ventilation of the cabin

#### 4.7. Flight at the flight level

At flight at the flight level it is necessary to count with big sensitivity of controlling agents and the reactions to the pilotage of the airplane change with the speed of the flight, the speed of TL 96 Star has a wide range.

#### **ATTENTION!**

**Do not perform any sharp turns with speed lower than 130km/h, with speed over 180km/h do not proceed any commotion with the controlling agents and use the maximum of 1/3 of its full displacement.**

Remark: if your cabin is equipped with circle side windows, test when they are turned into the direction of flight the aerodynamic noise in the cabin and the effectiveness of ventilation thank to the force ventilation of the cabin is very good.

#### 4.9. Descent

While descending from higher flight levels which lasts longer time we recommend not to descent at no load in order to protect the engine from cooling down, but to descent with slight tension of the engine with the speed about 180km/h.

Notice! The information contained in this document is for reference and information only.

The pilot is the final and only responsible party for the safe operation of this aircraft.

#### 4.8.1.Sideslid

the slip should be performed at the speed between 120 to 130km/h.

#### 4.9.Landing

Set the airscrew to small angle of incidence if your airscrew is adjustable, in case having to repeat the landing, your engine would have the full disposal of output.

Set the weighing of the airplane slightly heavy on the tale and fasten your seat belts.

After third round turn shift out the flaps at the speed 125-130km/h. After fourth round turn slightly snap and shift the flaps to the 2<sup>nd</sup> grade. at the speed of 105-110km/h. After shifting out, increase the speed snapping to 115-120km/h, and go to landing with this speed till long wind. The way you are losing the long wind, wind down the speed. Thank to the down-to-earth lifting force you will be bearing relatively slow, on the main undercarriage it will be around 75km/h. With sequent snapping of the gas lever keep the airplane as long as possible only on the main undercarriage. The proe wheel will lay on the ground on itself with the speed around 60km/h.

Remark: Shifting especially the 2<sup>nd</sup> grade flaps at slightly lower speed than is the maximum allowed speed for the 2nd grade speed expressively descent the power, which is necessary for this task.

Consecutive slight speed increase will enable to keep the direction of landing because the rudder is still adequately effective. If you will be coming to landing with too low speed / even though still with the backup against the stalling speed / you will find out, that the effectiveness of the rudder is descending and you will have more work with keeping the direction.

#### 4.10.Tasks after landing

- rom the place of landing taxi to the place of parking
- urn off all appliances, respectively horizon
- urn off the main switch
- lose the fuel supply to the engine with the fuel tap
- eave the lifting flaps shifted off on 2<sup>nd</sup> grade / this task seems to not be logical because we shift the flaps on the 1<sup>st</sup> grade before the start, but its purpose is to restrain the possibility of stepping of you own or your fellow-traveller while getting off the plane. The flap is fully shifted off and is expressively bended, the possibility of stepping on it is smaller /
- fter the airscrew stops, lock off the overlap of the cabin, release the seat belts and lift off the cabin. The airplane should stand against the wind when lifting the cabin. The overlap of the cabin has pretty big size and rapid wind directing to the overlap from the back could damage the hung up of the overlap of the cabin
- while parking the airplane, the cabin must be closed so the side or back wind would not apply load in the hung up of the cabin
- **ATTENTION!** do NOT leave aircraft canopy opened againts the sun, the plexy canopy will function as magnifying glass and will brun the top upholstary
- **ATTENTION!** Before leaving and locking the cabin lock and lock in the saving system

Notice! The information contained in this document is for reference and information only.  
The pilot is the final and only responsible party for the safe operation of this aircraft.

#### 4.11. Pilotage in lateral wind

If you will be flying with keeping the prescribed meteorological restrictions, the allowed values do not present any expressive barrier in order to take off nor land.

If you will have to land in stronger lateral wind use the technique of glide against the wind or the flight with lateral bending against the wind.

You can also use the possibility of landing at high revolutions than no load revolutions of the engine, its slight force of the airscrew expressively decreases the stalling speed.

If the adjustable airscrew is assembled, do not forget to set the minimum incidence angle before landing. If the landing runway is wide enough you can shorten the direction of lateral wind landing sideward to the axle of the runway.

#### 4.12. Flight in turbulent atmosphere

We do not overpass the speed 180km/h in turbulent atmosphere, do not fly even too slow / under 130km/h /. High speed can cause big force by the wind gust, small speed increase the danger of fall of the airplane while flying into the decreasing current of air.

If your airscrew is adjustable, set it on a smaller incidence angle and fly with higher revolutions of the engine, you will have the disposal of full output of the engine for case of deeper pancake landing in turbulence. Be ready to quickly add and detract the gas.

The flight in turbulence is stressing for the pilot and also for the airplane. If it is possible, you can mount to higher flight level, where most turbulences often disappear.

#### 4.13. Standing up to the plane

**The aircraft TL 96 Star is type of composite sandwich construction and it is necessary to observe reasonable manipulation of the aircraft. You must step on the wing only on marked antiskid walkway placed on each wing beside the cockpit. You are NOT allowed to step anywhere else, you are not allowed to kneel or sit on non of the wing since there is not applied a special reinforcement on the rest of the aircraft skin. Inadequate pressure may cause nonreversible and visible aircraft damage as dents in the sandwich.**

Stand up to the airplane one after another, care about standing persons not to stand up at one time. If both persons would weigh with their weight the footrest at one time, re -weighing to the tale could occur. Step on the wing only in the place where antislip strips are marked in.

### 5. Output

#### 5.1. Conditions for output assessment

Lower introduced values are valid only by the conditions of MSA at the sea level and for a steady flight and keeping the maximum taking off weight.

#### 5.2. Speeds

Stalling speed of the airplane in the landing configuration $V_{so}$	62km/h
Maximum never-exceed speed $V_{ne}$	275km/h
Maximum speed of horizontal flight with maximum steady output of the engine $V_h$	230km/h

Remember, that the maximum speed of the horizontal flight expressively decreases with the height of the flight. Maximum speed is influenced expressively by weight in height close to the ceiling and with overloaded airplane.



Notice! The information contained in this document is for reference and information only.  
The pilot is the final and only responsible party for the safe operation of this aircraft.

### 5.3. Rate of climbs and height loss from the beginning of stalling

The values of rate of climbs are valid for maximum weight of the airplane-450kg with maximum steady output of the engine and after the recount to the zero height by the MSA. With increasing height the rate of climb expressively decreases.

Rate of climb for the engine Rotax 912	4,6m/s
Rate of climb for the engine Rotax 912S	4,8m/s

The loss of height from the beginning of stalling in direct flight till reinstatement of the horizontal flight using the common procedures is 15m.

The loss of height by stalling in strictly flying turn at the bank of 30 degrees from the beginning of stalling till reinstatement of the horizontal flight is 20-25m.

### 5.4. Ceiling

Practical ceiling is 6500m with the airplane with engine Rotax 912 and 912S with the maximum taking off weight. Practical ceiling means the height of the airplane when it is able to be rising with the speed at least 0.5m/s.

### 5.5. Gliding range

Introduced value of the gliding range is valid for wooden 2blade airscrew and the speed of the flight 130km/h.

Gliding range with no load engine	16.8
Gliding range with turned off engine	15.2

When using other than introduced airscrew, especially 3blade is the real gliding range by no load engine slightly higher / principle of bigger tension/. and with turned off engine slightly lower / the principle of higher aerodynamic force /

### 5.6 Length of start

Introduced length of start is prescribed for the maximum weight 450kg, by dead calm, dry, straight and shortly cut lawn, with the position of lifting flaps prescribed for the start. There is prescribed the value of sticking off the launching area and for reaching the height of 15m.

Engine	After sticking off	Across the obstruction at the height of 15m
912	90m	290m
912S	75m	250m

### 5.7. Landing length

Introduced length of landing is prescribed for the maximum weight of 450 kg, by dead calm, dry and straight and short cut lawn and with the position of lifting flaps prescribed for the landing. There is a value for maximum effective braking / without blocking the wheels / and for the landing without using the brakes.

The length of landing with using the brakes	100m
Length of landing without using the brakes	300m

Do not forget the landing length will expressively elongate, if you try to land with wind in the back. If it is only possible, land always against the wind.

Notice! The information contained in this document is for reference and information only.

The pilot is the final and only responsible party for the safe operation of this aircraft.

### 5.8. Flight persistency

The persistency means the time of the flight which the airplane can fly without refilling the fuel. It is also a quotient of depleted volume of the fuel in tanks and the lowest hourly consumption. The efficient speed is pretty low and is not introduced in this handbook in order not to lead to flying at this speed in unquiet atmosphere. Do not replace the technical term of persistency for the real maximum length of flight which you can usually reach.

At the airplane of factual configuration /engine+airscrew+weight / the persistency expressively depends on the technique of the pilotage. Consider the data about the persistency of flight as informative. For the engine Rotax 912 and 912S is the flight persistency about 5.9hours.

The economics of the flight depends expressively on the effectiveness of the work of the airscrew. There are optimal revolutions of the airscrew and setting of the blades for each speed of the flight, when the airscrew has the biggest effectiveness. Lower, there is a table for the airscrew SR 2000xa.

Table of optimal speed at setting the blades from the smallest, which is 12 degrees, to the biggest, which is 22 degrees. Engine with the reductor at 1:1.27./Rotax 912,914/ is assumed. It is obvious that due to the output of the engine it is not possible to accomplish for all setting of all revolutions. The table introduces the speeds in km per hour in the slopes.

Revolutions of the engine                      Setting of the airscrew blades in degrees

	12	17	22
3500	78	110	141
3600	80	113	145
3700	83	116	149
3800	85	119	153
3900	87	122	157
4000	89	125	161
4100	92	128	165
4200	94	132	169
4300	96	135	173
4400	98	138	177
4500	101	141	181
4600	103	144	186
4700	105	147	190
4800	107	150	194
4900	110	154	198
5000	112	157	202
5100	114	160	206
5200	116	163	210
5300	119	166	214
5400	121	169	218
5500	123	172	222

The effectiveness of airscrew work optimisation is not enough to ensure the flight with relatively low consumption. Also the engine with exact effectiveness and its consumption is not increasing with the revolutions in linear way, but it is increasing slightly progressively. / it mostly grows between 3.500 and 5.500 revolutions /. We recommend to go through information in the operating handbook of the engine, which is a part of the delivery. Also, there are introduced all dependencies of the output of the engine on height of the flight and temperature of the air.

Notice! The information contained in this document is for reference and information only.  
The pilot is the final and only responsible party for the safe operation of this aircraft.

## 5.9. Flying range

The flying range initiated in steady speed 170km/h, on the land by adjustable three blade airscrew FITI and again recounted to zero elevation above sea-level by MSA. It is 740km for the engine 912 and 912S.

## 6. Maintenance and operating the plane

### 6.1 Parking

When parking at free area it is necessary to keep these instruction:

- close the tap of the fuel tank
- turn off all appliances, both ignition circuits and the main switch
- lock and lock off the saving system
- lock the cabin
- underlay the wheels from both sides
- at longer standing, or if the wind is expected with the speed over 6m/s, anchor the airplane by the point 6.2., put covers on the blades of the airscrew, and cover the Pitot tube with suitable cover
- if you are standing on sun, cover the cabin with suitable cover

### 6.2. Anchorage of the airplane

Anchore the airplane to sufficient strong anchore / screw anchor is recommended /with cables and straps. Anchore the airplane at these places:

- screw rings for anchors at down outer side of the wing
- fork of the front wheel
- back part of the body of the airplane by the strap

For anchorage of the back part of the airplane, use a trap which is wide enough and underlay it by a soft pad so the strap would not slide on the body of the airplane and damage the varnish.

### 6.3. Manipulation with the plane

You have received together with you airplane a manipulative shaft, which can be fastened to the stub axle of front wheel. Manipulate with the airplane with help of the shaft. Due to its low weight this manipulation is easy even for only one person. If the shaft is not at your disposition, it is allowed to move with the airplane this way:

- push on the leading edge of the wings to the distance of 2metres from the body
- pushing the back side of the body down, pick up the front wheel and turn the airplane

While going through narrow places, assistance of informed persons ensuring the manipulation with the airplane at the ends of the wings is necessary

Notice! The information contained in this document is for reference and information only.

The pilot is the final and only responsible party for the safe operation of this aircraft.

#### **6.4.Assembly and disassembly of the plane**

Assembly and disassembly of the plane could be done only by trained persons. Assembly and disassembly is recommended to perform only in unavoidable situations, connecting elements are easily worn.

##### 6.4.1.Disassembly of the plane

The disassembly of the plane is necessary to perform with the cooperation of two persons this way:

- lift off the sitting parts of the seat
- screw out the aileron connecting strut
- screw out the union bolt of the hinge of the spar
- release the excentric hinge of the spar turning the lever of the hinge for about 180 degrees
- take out the hinge of the spar of the center-section
- shift out the wings of the center-section
- dismantle the ball joint of the draw rod of the balance area drive
- release all insurance sheet metals of the disassembly hinge of the elevator
- compress the disassembly hinge of the elevator to our body through the cut out area and shift out the elevator to the back

##### 6.4.2.Assembly of the plane

The assembly of the plane should be performed by two persons in reversed order than the disassembly of the plane.

#### **ATTENTION!**

**All self-stop hunts with the nylon rings can be used only once. All metal can be used at maximum 3times after the compression of its cut out from the tongs.**

After the assembly, perform these tasks:

- check the whole construction, the geometry of the wing and elevator , check if they are not damaged and no unnatural force or stress do not occur at movement of the wings, flaps and elevator
- manually vibrate with each wing at its end, watch the undesirable occurrence of noise, cracking, airspace or deformations
- perform the before flight check up in its full length

#### **6.5.Washing and cleaning the plane**

After each flight day, or if necessary and during the course it is necessary to clean the airplane in this range:

- wash and rub off the blades of the aircrew from the sedentary dirt
- wash, rub off and furbish the glass parts of the cabin, use only one bucksin leather which is often washed in clean water
- wash and rub off the leading edges of the wings and tale areas
- clean the bottom part of the body behind the front undercarriage leg
- remove incidental grass which can be intercepted on the undercarriage
- clean the interior of the cabin and take away the rubbish from the storage places

Notice! The information contained in this document is for reference and information only.

The pilot is the final and only responsible party for the safe operation of this aircraft.

- in need, clean other parts of the airplane, especially the upper sides of the wings and suction openings of the engine

Use lukewarm water for washing the airplane, change it often. First, wash the parts of the airplane and then rub them off. For cleaning the parts of the airplane from flies, use the same agents as used for cars for such purposes.

About once a month conserve the airplane with the agents used for cleaning and conserving the body of cars, including the glass parts and the airscrew. Clean the cabin with vacuum-cleaner and check if there are no undesirable objects in the back.

Wait for about one month with new airplane to conserve it so the varnish could solidify.

Remark: cover the Pitot tube while washing the airplane to protect it from water

### **6.6.Before flight inspection**

The before flight inspection starts on the left side of the cabin and proceed in the way clockwise. Perform this inspection and tasks:

the overlap of the cabin: check the cleanness, damage of the overlap, possible faults on locking

cover of the engine: take off its upper part, check the screws of the hang up of the engine bed. check the cable hang up, connection of the connectors, hang ups on the accumulator. Check the tightening of the fuel hosepipe, air filter, exhaust stroke hang up / tightening the screw of the dashpot stirrup, check up the spring integrity of the exhaust stroke piping /, check the tightness of oil cooler and the cooling liquid cooler.

Check the untightness of the sparks which could signalize its slacking. Check in need refill the oil, cooling and brake liquid, and also the level of battery solution in the accumulator. The cooling liquid should reach 2/3 of the maximum volume of the tank / at cool engine /. The oil level must be between the signs min and max and can not be lower than min. Before longer operation with the airplane it must be at least in the middle between the signs min and max.

Check possible fouling of the fuel filter, change it if necessary. If you recognize the fuel filter fouling in the engine space, perform extraordinary inspection or change the fuel filters of the subsidiary tanks in the interior of the cabin. Assemble the cover of the engine. Check the locking of the tap, the oil and cooling liquid level. Watch possible rubbed places on the pipe especially at hung up places, or at places where they are connected to metallic parts of the engine.

Check attentively the linking of the carburettor with the dashpot stirrup thank to the rubber pipes. If you find out that some of the pipe releases at the neck of the carburettor even though it had been tightened, it is necessary to take it off and change the introduced way / see the maintenance /.

**If the pipe is rubbed conically, it is necessary to assume that the small parts of the rubber could have gotten in to the carburetor stirrup. Entrust its cleaning and setting to special firm.**

**Propeller:** check the hang up, possible damage, airscrew cone hang up, if the airscrew is electronically adjustable, check if it does reconstruct

Notice! The information contained in this document is for reference and information only.

The pilot is the final and only responsible party for the safe operation of this aircraft.

**Nose wheel:** check the symmetry, malformation and airspace, tightening the cover of the front wheel, the integrity of varnish of the nut of the secure screw of the front wheel, tightening the nuts of the hinge of the front wheel

**Right wing:** check the knots of the center of the plane / after lifting up the seats in the cabin / , flaps and small wings hang-ups / you will probably have to kneel or lie down, the hangs up are not visible from the top / , check its airspace and the free movements, check the state and ensuring by the cotter pins at all flap hinges and small wings. Check the unity position of the lifting flaps at all positions on both wings.

**Right side of the body:** check the fuel tap, the surface of the airplane , possible flaws in the body or in the varnish

**Tale area:** check the free movement, weighing function, surface damage, the steer hang ups, the position of the elevator and the rudder / geometry /. The airspace of the elevator at pivots and the airspace of the rudder / no airspace at the pivot / , check the rivet connection of the tow bar at the weighing area. Check the total screw connection of the mechanization of the tale areas in the space between the elevator and the rudder. / from top /. / nuts, screws, possible flaws in the varnish /

**Left side of the body:** the same as the right side, locking the assembly hole, the rudder

**Left wing:** the same as the right wing

**The interior of the cabin:** check the cleanness, the airspace of the pilotage, the appliance functioning, the perfection of the board documents

**Tyres:** check the pattern of tyres, cracks, bulges and the pressure. For both tyres, the prescribed pressure is .1.2KPa.

## Screw connections, hinges, springs

### 6.7. Filling the fuel

Due to the composite construction of the airplane, increasing occurrence of the static electricity is possible, while filling the fuel, keep this procedure:

- make sure there is no open fire near the airplane especially make sure no one is smoking near the cabin
- get ready fire- extinguisher suitable for flammable fuels
- make sure the grounding cable placed on the right undercarriage leg is reaching the ground
- fill the fuel only from prescribed and approved containers for its storage, use the funnel approved for petrol only, it can be grounded with the grounding pin to the ground. / do not use plastic jerrycans nor funnels, with no certification for petrol /
- while filling the fuel, do not use the clothing which support the production of static electricity / synthetic fibers and etc. /
- check the turning off of all electrical appliances, ignition circuits and the main switch
- close the fuel pipe
- unlock and screw out the fuel tap
- edge in the filling neck the funnel approved for filling the airplanes with the buckskin refill filter

Notice! The information contained in this document is for reference and information only.  
The pilot is the final and only responsible party for the safe operation of this aircraft.

### **ATTENTION!**

**Do not use the filter with the filter refill from synthetic fibers!**

- slowly pour the fuel, pay attention and terminate to minimum specking the airplane by fuel. While filling, do not shore up your hands nor the container with the fuel on the wing, the sandwich cover is not proportioned for high area force
- after filling the fuel, take out the funnel after its total depletion, screw down the tap of the tank and lock it, wipe the rest of the fuel

## **7. Service life of airplane and maintenance periodicity**

Regular and carefull proceeding of the maintenance is the principle of reliable and safe operating of the airplane. The garantee inspection and the inspections after 100 and 300 hours should be written down to flight book.

### **7.1. Service life of the plane and its parts**

The service life as one part consist of the service life of decisive parts which are the airframe, engine and the airscrew. Wear of the airplane depends on its stress and that's why you should keep away from high stress on the construction, especially by high flight multiples. Do not disassembly the airplane needlessly and anchore the airplane only introduced way. Also keep away from landing in high lawn, which can expressively take the trouble on the airscrew.

Regular conservation with high quality car vosk expressively terminates aging of the varnish. Park the airplane in covered hangar if possible, at least, protect the airplane against unfavorable influence by covering.

There is no limit life on the airframe.

There is no service life of the engine. The engine is subject to revision after every 1200 hours in a service center, where is the service life specified.

The service life of the airscrew is not set, it undergoes regular revisions at the producer. The service life will be specified due to its factual state.

### **7.2. Workaday maintenance**

When buying a new airplane, check especially tightening the pipes on the engine and the state of the fuel filter. Check also carefully all places where the pipes are taped to metal parts of the engine-for example suction piping.

### **ATTENTION!**

**Change the fuel filter preventively after first ten flight hours.**

We can not exclude the possibility of getting dust or other dirt into the tank of the fuel system while producing the airplane. First rinsing of the tank and the fuel system before the filter can bring its exceptional contamination. If your airplane is equipped with tanks in the wings, each of them is equipped by independent fuel filter. These filters are approachable after taking off the seats. Check these filters and change them preventively after 150litres of fuel overdraft. / from each tank /

Use preferentially filters with clear housing. Workaday maintenance consists of before flight inspection and the engine test, they are introduced in point 6.6.

Notice! The information contained in this document is for reference and information only.  
The pilot is the final and only responsible party for the safe operation of this aircraft.

### 7.2.1. Lubricant plan and lubricant preparation

For lubricating the engine, use only the oil prescribed by the engine producer and introduced in the maintenance of the engine handbook. Type of initial oil filling is introduced on the hand down print out and is also written on the label of the control tap of the upper part of the engine cover. Frequency of changing the oil in the engine is every 100 hours.

For other lubricating places, it is possible to use any plastic lubricants or any transmission oil. To make the lubricating of worse approachable places easier, / hang ups, fill the syringe with oil and for the application use a needle with bigger diameter. It is enough to apply only 1-2 drops of the oil. In many places, the oil serves as a conservative agent so data written in the bottom use only for your orientation and tend to factual state of the lubricating area.

Lubricating areas:

Place	Type of lubricant	Frequency
Front undercarriage leg	plastic lubricant	once a year
Aileron hang ups	transmission oil	after 50 hours
Upper and bottom rudder hang up	transmission oil	after 50 hours
Elevator hang up, weighting	transmission oil	after 50 hours
Pilotage joints	transmission oil	after 50 hours
Aileron joints	transmission oil	after 50 hours

You can reach some lubricating places after taking off the seats in the cabin, others are approachable after taking off the auditorial opening on the left side of the body in front of the elevator.

### 7.2.2. Blocking, raising and jogging along preparation

The shaft for manual hauling on the ground was delivered with your airplane. Special blocking nor elevating appliances are not used in normal maintenance of the airplane.

### 7.2.3. Disassembly of the nose wheel

The disassembly demands the cooperation of two persons. Prepare the bracket under the support points by the point 7.7., ensuring wedge and selfprotecting nut M14.

While disassembling proceed this way:

- ensure the wheels of the main undercarriage by the wedges from both sides
- take off the upper and low part of the engine cover
- slacken one of the nuts from the front wheel axle and screw it out
- compressing the upper part of the body in place in front of the tale areas and relief the front wheel, shore up the engine bed in the place by the point 7.8.
- extrude the axle from the relief wheel and take the wheel out



Notice! The information contained in this document is for reference and information only.

The pilot is the final and only responsible party for the safe operation of this aircraft.

While assembling the front wheel, proceed it reversed way. The old nut should be replaced by new one, also perform the signature of the nut position on the hinge with color.

#### 7.2.4. Wheel disassembly of main undercarriage

The disassembly demands the cooperation of two persons, for assembly prepare the bracket, ensuring wedges and selfprotecting nut M14.

- ensure the second wheel of the main undercarriage by the wedges from both sides
- raise the airplane on the wing at the side of the disassembling wheel and support it under the wing by the point 7.8.
- release the inside nut of the hinge of the wheel and lift up the hinge of the wheel from the undercarriage leg / without lifting up the hinge with the wheel, the back inside screw of the wheel cover would be able to be screwed out poorly /
- disassemble the wheel cover hanged up with 3 screws M6
- screw out 2 screws with the spring and with the inside hexagonal with which is fastened the brake valve on the braking shield
- lift up the inside braking plate to the direction down and take it out of the brake valve
- take out the brake valve from the braking disk by compressing to back
- screw out the inside nut of the hinge of the wheel
- take out the wheel from the axle

While assembling proceed the reverse sequence.

#### 7.2.5.Mending the tyre

Do not use same agents as for the mending the car tyres which necessitate 30minutes of turning the tyre, in case of emergency tyre mending. This condition can not be ensured. We recommend to change the damaged tyre for a new one, or to change it for expertly mended tyre.

#### 7.2.6.Electrical system voltage

Basic electrical installation on the plane is with the voltage of 12V and two wire conductors. The electrical installation is equipped with no individual fuse. The switches used in the el. system / main switch, all appliances, ignition circuits / function as fuses. Some of the electrical appliances / for example the transmitter is ensured by its own appliance fuse /. If the voltage decreases while switching on the appliances / for example while adjusting the airscrew , the Flydat drops out / check the cleanness and tightening of the connection of battery and the level of electrolyte. If the fault remains, contact the service center of the producer.

#### 7.2.7. Tolerance and setting up values

Distance of electrodes of the sparks	0.7mm
Inflating the pneumatic tyres	2.0kPa

#### 7.2.8. Supporting and subordinate construction

Notice! The information contained in this document is for reference and information only.

The pilot is the final and only responsible party for the safe operation of this aircraft.

Wings, tail areas and the body are considered as the supporting constructions. Non-supporting construction is the upper and the lower cover of the engine, covers of the undercarriage wheels and the aerodynamic cover of the front undercarriage leg. There can not be any interference made with these supporting constructions from the side of the user without the producer's approbation.

#### 7.2.9. Special assembly, controlling and setting preparations

It is enough to use normal workshop tools and accessories for the maintenance of the airplane made by the user.

#### 7.2.10. Special tools

The barrel spanner for the sparks is part of the delivery. Other special tools are not prerequisite for normal maintenance made by the user.

#### 7.2.11. Materials for small reparations

With regard to the type of the construction only small reparations can be made on the surface of the airplane. For these reparations, use two component mastic. Clean and ungrease the damage surface with technical petrol and cement it with the mastic prepared by the direction to use. After dispersion hardening rub the mastic and varnish it.

#### 7.2.12 Changing the fuel filter in the engine area

We can not say how often the fuel filter should be changed, because it depends on how well you filter the fuel while filling the tanks.

That's why use fuel filters with clear housing only, you can see the fouling of the filter. After the first change of the filter / 12 hours the longest / change the filter after every 50 hours preventively.

### **ATTENTION!**

#### **Perform the filter change on a cool engine only**

The progress while changing the fuel filter:

- close the fuel delivery
- take out the upper cover of the engine
- release the buckles on the petrol pipes on both sides of the filter, leave the buckles on the pipes
- take out the filter while turning the pipes smoothly, take care about the leaking fuel from the pipes / you can close the pipe temporarily by compressing the screw shank M6
- slip on the pipes on the filter and compress their ends to the body of the filter
- slip on the buckles on the pipes in place of mouthpiece of the filter and tighten the buckles, make sure no buckle is disvalued by the slipped thread or any other way
- ensure the buckles of the filter against the axle dislocation by the ensuring wire
- after changing the filter let the engine operate for five minutes with no load, then turn it off and make sure the filter is filled with petrol
- assemble the upper cover of the engine

Remark: If you will not close the fuel delivery while changing the filter, all the petrol between the part of the fuel pipes and the filter and the fuel tank will leak back to the tank, the self-priming pump will needlessly suck the fuel from the tank to the system for very long time.

Notice! The information contained in this document is for reference and information only.  
The pilot is the final and only responsible party for the safe operation of this aircraft.

### **ATTENTION!**

**After changing the fuel filter pay extra attention to the engine test before flight to make sure the fuel system is functioning.**

#### 7.2.13 Maintenance of propeller SR 2000 xa

It is necessary to make a visual control of the state of the propeller, of the blades, leading edges, state of the base parts of the blades in the place of hang up to the airscrew head after every 10 hours of operating. At normal maintenance, clean the blades with normal cleaning agents the way to get rid of the dirt.

#### **7.3.Contract revision**

Introductory revision is made after first 25 flight hours by the producer in his service center. Performing this revision by the producer is another condition for another guarantee of the airplane. The range of this revision is prescribed by the internal rule of the producer. Also the change of the filter and oil is made on the engine.

#### **7.4.Periodical revision after every 50hours**

The revision after every 45-55 flight hours is performed by the user of the airplane if he was trained for the maintenance of the airplane, otherwise the revision is made in the service center of the producer. The revision consists of these tasks:

- the before flight revision in its full length
- revision of all screw and hinge connections
- visual revision of back side of the body in the interior
- revision of the fuel installation, check the tightness of the connections, pipe state and the cleanness of the fuel filter
- revision of the engine hang up and also all its sets
- setting-up of the brakes
- work on the engine by the handbook of the engine

#### **7.5.Periodical revision after every 100hours**

The revision after every 95-100 hours or after 12 months from the last revision is made by the user if he was trained for the maintenance, otherwise the revision is made in the service center of the producer.

The revision consists of these tasks:

- revision after 50 flight hours
- careful revision of the airframe of the airplane and correction of small damages
- visual inspection shock absorber system's components of the nose landing gear
- revision of the glazing of the cabin and its interior
- revision of the pilotage, airspaces, deformations and incidental mending or setting
- work on the engine by the engine handbook
- change of the oil and the oil filter
- revision and service of the airscrew at the producer
- flight test by the probationary pilot

#### **7.6.Periodical revision after every 200hours**

The range is the same as the revision after 100 hours, but also the ignition sparks are changed.

Notice! The information contained in this document is for reference and information only.  
The pilot is the final and only responsible party for the safe operation of this aircraft.

### **7.7.Periodical revision after every 300hours**

This revision is made after every 295-305 flight hours or after three years of operating. The diagnostics of all stressed parts of the construction is made and also its detailed range is prescribed by the internal rule of the producer by the detected state. We introduce here basic tasks for your information:

- revision after 100hours
- taking off the airscrew and the engine
- revision of the construction
- revision of the interior of the body and the cabin
- the outer revision of the whole airframe
- pilotage revision
- replacement of intended parts
- flight test by the probationary pilot

### **ATTENTION!**

**This revision is made only by the service center of the producer.**

### **7.8.Jacking points on the plane**

The jacking points made by the low inside buckles of the engine bed to the body partition are made for lifting the front undercarriage. These jacking points are approachable after taking off the low part of the engine hood. Do not forget about ensuring the wheels of the main undercarriage by the wedges on both sides while supporting the airplane on these points.

The jacking points prescribed for the lifting are placed on the low part of the wings in the distance of 190cm from the body. The supporting mean must be made of a hard construction, it must be at least 100mm wide and 1000mm long. This supporting part, which supports the wing must have a soft, 20mm thick felt cover, which enables the weight of the supporting part of the airplane to disintegrate to its whole area.

After interposing the support under the supporting area, we lift the wing on its low end part by arms the way to let the lifting force disintegrate on its whole length.

The main undercarriage wheels can be supported by the low parts of the spring constituting the main undercarriage.

### **7.9.List of labels and their placing**

- the producer label of the body is placed on the inner left side of the airplane in the area behind the pilot's seat.
- producer label is placed on the partition behind the seat of the fellow-traveler
- the label introducing the maximum weight of the crew and the load in the dependency of filling the fuel tank is sticked inside on the left front part of the cabin
- the label indicating used engine oil is on the control tap of the upper cover of the engine

Notice! The information contained in this document is for reference and information only.

The pilot is the final and only responsible party for the safe operation of this aircraft.

## **8. Airplane repairs**

### **8.1. Repairs of connection screw**

In case of corrosion, flexion, cracking of the screw, it is necessary to exchange it. When the slip thread occurs, it is necessary to exchange the screw and the nut. Replacing the screw is allowed only with the screw same quality and norm. Self-ensuring nuts with plastic circle are only for one use. All-metal nuts can be used maximally 3 times and after compressing the ensuring circle with tongs.

### **8.2. Repairs of rivet joints**

When the rivet joint is damaged / released or asperated /, it is necessary to remove the damaged rivet or its remainder, check if the connection places are not damaged and rivet the connection. If the rivet connections are damaged, it is necessary to replace the parts or consult the reparation with the producer of the airplane. Use the same quality and type of rivet when mending them.

### **8.3. Pilotage repairs**

Pull bars, connection parts, iron ropes, bearings and other parts can not be damaged in any way. Individual parts can be replaced only by original parts delivered by the producer. Any other relevant damage of pilotage or if bigger airspace in the pilotage occurs, the service center of the producer can repair them. After any reparation of the pilotage, flight test with a probationary pilot must be done.

### **8.4. Airframe repair**

The damaged surface should be cemented, rubbed and varnished when it is damaged slightly. When perforation of nonsupporting parts occurs, / low part of the engine, wheel covers, cover of front undercarriage wheel /, the reparation is done by laminating one or two layers of the laminate, the cement, rub down and varnish the surface. The cementing should be done with two component car mastic and by the direction for use.

Deeper damages of the airframe or its perforation are necessary to be consulted with the producer, who will consider the influence of the damage on the resistance of the construction and will determine the way of reparation.

### **8.5. Fuel system repairs**

When finding the untightness of the fuel system or its passage, the reparation must be done immediately. Sensible fault, for example released sleeve coupling of pipes, filter fouling, can be repaired by the user of the airplane. Other reparations can be done only in the service center of the producer.

### **8.6. Engine repairs**

All reparation of the engine and its aggregates can be performed only the service center of the producer. These types of faults can be signalized by unnatural noise from the engine bed, increased vibrations, revolution fluctuation, engine misfire, lower output, bad smell /scald /, the engine values are out of operating regime, bad starting and etc.

### **8.7. Electroinstallment and appliance repairs**

In case of electroinstallment fault, the user can make reparations such as charging the battery, cleaning the contacts and connections of disunited connectors. Other reparations of the

Notice! The information contained in this document is for reference and information only.

The pilot is the final and only responsible party for the safe operation of this aircraft.

electroinstallment and other appliances can be performed only by the service center of the producer.

### **ATTENTION!**

**All reparations must be written down in the flight book. All damages which have influence on the stability of the construction and the flight characters are necessary to be announced to the producer, which will determine the reparation.**

### **8.8.Revision of electroinstallment**

All cable connections by the connectors must be checked if they are not damaged, released or corrosive, also check the reliability of tightening to the construction. If the connectors are corroded, let them exchange expertly.

Check the possible damage of cables by the heat or rubbing off. Check if all connectors of the sparks are tightened to the body of the spark. Release of the connector can be the reason of its burning and failure of functioning.

Check the level of electrolyte in the battery in each parts and fill it with distilled water if necessary. Recharge the battery regularly if the plane stand off for longer time.

### **9.Engine Rotax 912/912S maintenance**

There are most information and derection needed for the operating of the engine Rotax 912/912S in the handbook for using the engine which was delivered to you with your airplane. Keep the engine in cleanness and watch out incidental leakage of oil which can signalize the necessity of expert maintenance of the engine. We introduce only the basic tasks for the maintenance.

#### **9.1. Oil refill**

- exchange the filter when changing the oil
- first oil exchange is made after first 25 flight hours, The oil refill of the reductor is united with the oil refill of the engine
- the oil exchange is made after every 100 flight hours or once a year
- the amount of the oil refill for exchanging is 3 liters

The handbook for maintenance of engine Rotax 912/914 requires after each exchange of the oil to cut the old filter before its liquidation so the flashes can not arise. The filter should be taken out, unfolded and looked through, if it does not contain any metallic splints, scraps of tamping, and etc. which could be a presage of the engine failure.

We recommend to let this work have done by an expert technician.

#### **9.2.Sparking plugs**

The revision and cleaning of the sparking plugs should be done every 100 hours of operating and when the starting of engine is worse. The distance of electrodes is 0.7mm.

The state of the sparking plugs at the revision can signalize worse state of the engine or its work in not convenient environment / temperature, fouling of the air filter, untightness of valves /. Correct color of the sparking plugs is light to brown.

Exchange of the sparking plugs is done after every 200 hours of operating at the regular revision.

The company Rotax prescribes to cover the screw with a paste improving the transfer of heat between the body of the spark and the head of cylinder before assembling new sparking plugs.

Notice! The information contained in this document is for reference and information only.

The pilot is the final and only responsible party for the safe operation of this aircraft.

If you do not have such agent, we recommend to let this work have in a expert company, or buy sparking plugs which are already covered with such paste.

### **9.3.Refrigerating liquid**

We use the same refrigerating liquid as for water refrigerated car engines and by the direction for use, in the concentration of 50%.

### **9.4.Service life of the plane, revisions and inspection of the engine**

Use the liquid with anti corrosive ingredients prescribed for the block of engines from aluminum base alloys. Do not use the refrigerating liquid in bigger concentration, it can be detrimental for individual parts of the refrigerating system.

The refrigerating liquid density should be checked before the beginning of winter. Fill the refrigerating liquid to the tank.

#### **ATTENTION!**

**Do not open the tap of the refrigerating liquid tank in hot state. You can get burnt easily.**

While letting out the refrigerating liquid it is necessary to open the tap of the tank and screw out the low tightening screw / with the impermeable ring / of the water pump. Then it is necessary to release the low pipe of the cooler of the refrigerating liquid / which is located lower than the engine / to let the old refrigerating liquid leak out, after letting it out, put the pipe back on the cooler and tighten the buckle carefully. While exchanging the refrigerating liquid it is also necessary to exchange the tamping under the low tightening ring of the water pump. This screw is tightened by the moment of 10Nm.

### **9.4. Service life, revision and engine revisions**

The producer prescribes the engine revisions after 25,50,100 and 200 hours with the tolerance + - 10hours. These tolerances can not be added. The service after 100 hours is also done at least once a year no matter how many flight hours had been reached.

The revision after 25 hours is performed on a new engine and on engine after general overhaul. The extension of prescribed revisions is introduced in the original handbook 'Wartungshandbuch fur Rotax Motor Type 912 Serie', which is a part of the delivery. It is a shop handbook which is not indicated for instant user. There is no translation of this handbook and its producer suppose that the prescribed maintenance of the engine will be performed by the authorized technician.

The revision after 25 hours of operating is combined with the exchange of the oil and the oil filter. The service of the engine after 50 hours is not recommended by the producer, with the exception for the engine with the fuel AVGAS, when is also necessary to exchange the oil after 50 hours of operating.

#### **ATTENTION!**

**The engine producer prescribes after every exchange of the filter to cut the old filter, it should be taken out, unfolded and looked through, if it does not contain any metallic, steel, bronze or aluminium splints, scraps of tamping, and etc. Occurrence**

Notice! The information contained in this document is for reference and information only.  
The pilot is the final and only responsible party for the safe operation of this aircraft.

**of these parts in the filter signalize usually increased wear out or damage of the engine.**

Some of the tasks performed at the revision after 100 or 200 hours can be done only by a authorized technician. We recommend to let these revision have done in authorized service of the engine producer, or you can find them out through our company.

**ATTENTION!**

**Condition for incidental successful reclamation of the engine faults is keeping prescribed revision and work on the engine only the way the producer of the engine prescribed, or by the authorized technician. We recommend you at least in the time of guarantee period to let all work on engine have done by authorized technician, or to ensure the revision through our company.**

**9.5.Service life of rubber parts of engine**

All rubber parts of the engine should be changed after 5 years from the date of producing the airplane.

This time restriction of the service life of the rubber parts of the engine is independent and completing to its visual revisions, let these changes have done by authorized service of the producer of the engine, or ensure them through our company.

- END -