

# TL-ULTRALIGHT

Letiště, budova 84  
503 41 Hradec Králové

tel/fax: +420 4952 13378

tel +420 4952 11753

tel +420 4952 18910

info@tl-ultralight.cz

www.tl-ultralight.cz

## TL - 2000 Sting Carbon

### Flight and operational manual

1st Published in December 2000

Translated to English - January 2001



Serial number:

Registration number:



<b>1. GENERAL INFORMATION</b>	<b>7</b>
1.1. Important Information	7
1.2. Description of the aircraft	7
1.2.1. Airframe	7
1.2.2. Fuel system	8
1.2.3. Propeller	8
1.2.4. Engine	8
1.2.5. Control movements	8
1.2.6. Basic technical data of the airplane	9
1.3. Layout of the airplane	9
1.4. Detecting the center of gravity position, allowed and measured values	10
1.4.1. Weighing the airplane for the foreword center of gravity position	10
1.4.2. Weighing the airplane for the backmost center of gravity	11
<b>2. OPERATING RESTRICTIONS</b>	<b>11</b>
2.1. Flight operation speeds and position fault of the Air Speed Indicator	11
2.1.1. Air-speed data and position fault of Pitot tube	12
2.1.2. Reparation table of real and indicated air-velocity in km/h	12
2.2. Weights and loads	12
2.2.1. Maximum and minimum weights	12
2.2.2. Weight of the empty airplane and detected position of the point of balance	12
2.2.3. Positioning of the load	12
2.3. Engine operating restrictions	13
2.3. Propeller operating restrictions	13
2.4. Fuel and lubricant oil	13
2.4.1. Fuel supply	14
2.4.2. Consumption of fuel	14
2.5. Restriction of maneuver	14
2.5.1. Allowed turns	15
2.5.2. Flight multiples	15
2.6. The crew	15
2.6.1. Minimum and maximum weight of the crew	15
2.6.2. Pilot's qualification	16
2.6.3. Pilot's place on the plane, age of the crew, using the seat belts	16
2.7. Maximum flight height	16
2.8. Meteorologic condition restriction	17
2.9. Carriage of restricted goods	17



2.10. Types of airport traffic .....	17
<b>3. EMERGENCY PROCEDURES .....</b>	<b>18</b>
3.1. Misfire of the engine.....	18
3.1.1. Failure of the engine during the flight to the height 200m.....	18
3.1.2. Failure of the engine during the flight above the height 200m.....	18
3.2. Fire on board of the plane .....	18
3.3. Vibrations .....	19
3.4. Undercarriage failure .....	19
3.4.1. Main undercarriage failure .....	19
3.4.2. Front undercarriage failure.....	19
3.5. Using the saving system .....	19
<b>4. OPERATING PROCEDURES .....</b>	<b>20</b>
4.1. Starting up the engine.....	20
4.2. Engine test .....	21
4.3. Important parts made before getting off .....	21
4.4. Taxiing .....	22
4.5. Taking-off .....	22
4.5.1. Maximum power of wind at time of taking off.....	23
4.6. Tasks after reaching the flight level .....	23
4.7. Flight at the flight level .....	23
4.8. Descent.....	23
4.8.1. Sideslip.....	23
4.9. Landing.....	24
4.10. Tasks after landing.....	24
4.11. Flying in lateral wind .....	24
4.12. Flight in turbulent atmosphere.....	25
4.13. Standing up to the plane.....	25
<b>5.PERFORMANCE.....</b>	<b>25</b>
5.1. Assumptions for performance calculations .....	25



5.2. Speeds .....	25
5.3. Rate of climbs and height loss from the beginning of stalling.....	25
5.4. Ceiling.....	26
5.5. Gliding range.....	26
5.6. Length of start.....	26
5.7. Landing length .....	26
5.8. Maximum Endurance .....	27
5.9. Flying range .....	27
<b>6. MAINTENANCE AND OPERATING THE PLANE .....</b>	<b>28</b>
6.2. Anchorage of the airplane .....	28
6.3. Manipulation with the plane .....	28
6.4. Assembly and disassembly of the plane .....	28
6.4.1. Disassembly of the plane .....	29
6.4.2. Assembly of the plane.....	29
6.5. Washing and cleaning the plane.....	30
6.6. Before flight inspection .....	30
6.7 Filling the fuel .....	33
<b>7. SERVICE LIFE OF AIRPLANE AND PERIODIC MAINTENANCE.....</b>	<b>34</b>
7.1. Service life of the plane and its parts.....	34
7.2. Daily maintenance .....	35
7.2.1. Lubricant plan and lubricant types .....	35
7.2.2. Ground Handling .....	36
7.2.3. Removal of the front wheel .....	36
7.2.4. Wheel disassembly of main undercarriage .....	36
7.2.5. Mending the tyre.....	37
7.2.6. Electrical system voltage.....	37
7.2.7. Tolerance and setting up values .....	37
7.2.8. Supporting and subordinate construction .....	37
7.2.9. Assembly of the aircraft.....	38
7.2.10. Special tools.....	38
7.2.11. Materials for minor repair to the aircraft surface repairs .....	38
7.2.12 Changing the fuel filter in the engine area .....	38
7.2.13 Maintenance of SR 2000 Woodcomp Propeller.....	39
7.3. Warranty Service .....	39



7.4. Periodical revision after every 50hours .....	39
7.5. Periodical revision after every 100hours .....	39
7.6. Periodical revision after every 200hours .....	40
7.7. Inspection after every 300hours .....	40
7.8. Jacking points on the plane .....	40
7.9. List of labels and their placing.....	40
<b>8. AIRPLANE REPAIRS.....</b>	<b>41</b>
8.1. Repairs of nuts and bolts .....	41
8.2. Repairs of rivet joints .....	41
8.3. Control system repairs .....	41
8.4. Airframe repair .....	41
8.5. Fuel system repairs .....	42
8.6. Engine repairs.....	42
8.7. Electronic and appliance repairs .....	42
8.8. Inspection of electrical system .....	42
<b>9. ENGINE ROTAX 912, 912S AND 914 MAINTENANCE .....</b>	<b>42</b>
9.1. Oil refill .....	43
9.2. Spark plugs .....	43
9.3. Refrigerating liquid.....	43
9.4. Service life of the plane, revisions and inspection of the engine .....	43
9.4. Service life, revision and engine revisions.....	44
9.5. Service life of rubber parts of engine.....	45

**T L - 2000 Sting Carbon**  
**s/n 07 ST 233**



Dear Aircraft Purchaser,

I would like to compliment you on the purchase of the ultra light airplane TL-2000 Sting Carbon which is the result of many years of development by our company. The company TL-Ultralight strives to be a leading supplier of quality aircraft both in the Czech Republic and worldwide.

The TL-2000 Sting Carbon provides outstanding performance in the small sports airplanes category, flying in the TL-2000 Sting Carbon is very economical and its maintenance is also much easier than conventional aircraft.

I believe that the airplane will be very satisfying and provide you with years of pure enjoyment. This Flight manual and operating guidebook should help you become familiar with your new aircraft, please study and become familiar with this manual and the respective manuals for the propeller and rescue system if fitted.

I wish you a lot of joy from flying with your new airplane the TL-2000 Sting Carbon.

In Hradec Králové July 24.4.2001.

TL Ultralight L.T.D.

Jiří Tlustý



## 1. General Information

In case this guidebook refers to the rule UL1, UL 2 or UL 3, it is only referring to the corresponding rules of Letecké amatérské asociace české republiky – Czech Republic amateur flight association. This association is controlled by Úřad pro civilní letectví-Office for civil aviation Czech Republic.

### 1.1. Important Information

Every airplane owner, operational organization and pilots who fly this TL-2000 Sting Carbon must acquaint with this guidebook at its full length. This manual consists of flying and maintenance for this type of airplane. This manual must be on board of the plane with other documents for all flights.

It should be kept with the operating instructions for engine, propeller and the rescue parachute system if fitted.

This airplane is intended to be used for sports and recreational purposes. Also for performing basic and advanced flight training. It is certificated by technical guideline UL 2 and it is not allowed to make commercial flights with the exception of training and hire.

This manual is only valid if any changes sent to the aircraft owner are put into this manual. Superseded pages should be changed in the manual.

## **ATTENTION**

**This airplane belongs to the sports and recreational category and is dateless to the approbation of UCL v ČR-Office for civil aviation in Czech Republic. Operating this airplane is at your own risk.**

### 1.2. Description of the aircraft

#### **1.2.1. Airframe**

The TL-2000 Sting Carbon is two-placed all composite low wing plane with flowing elevator.

The fuselage is laminated, in some places made into sandwich, with oval cross section shaped to achieve the best proportions whilst maintaining rigidity, low weight and low aerodynamic drag. There is an integrated fuel tank just forward of the seats in the base of the fuselage.

The undercarriage has three wheels with hydraulic disk brakes on the rear wheels. The main wheel suspension is from laminated composite spring. The front wheel is steerable. The brakes are foot-operated from the pilot's side only, each wheel can be braked separately. The wheels can be equipped with aerodynamic covers and wheel spats.

The cabin is arranged with seats next to each other – side-by-side, it is covered with a large canopy which may be either clear or tinted, which provides an exceptional view. Locking of the cabin is done at three points. The pilot controls cockpit ventilation from the vent at the front of the canopy, the aircraft can also be equipped with rotating vents or sliding windows for additional ventilation.

The controls for the airplane are duplicated, arranged with a joystick centrally located between the pilots and passengers legs. A control rod controls the elevator; rudder is controlled by wires, the ailerons and flaps are controlled by control rods.

The wing is all composite with aileron and flaps being made from composite material. The flaps operate in two-positions.

The elevator is also composite; it is supplied with a trim tab, and provides the longitudinal trim of the airplane. The design of the elevator contributes to the low aerodynamic drag of the airplane.

**T L - 2000 Sting Carbon  
s/n 07 ST 233**



### **1.2.2. Fuel system**

The fuel system consists of an integrated composite fuel tank in the fuselage. It is supplied with fuel meter, on/off cock, filter and mechanical fuel pump for engine types 912 and 912S. The 914 Turbo fuel supply is supplied electrically through a supplemental electric pump.

The fuel tank is equipped with lockable lid placed on the front right side of the fuselage.

### **1.2.3. Propeller**

It is possible to use a fixed pitch or in-flight adjustable propeller. The manual for your propeller is provided with the airplane as is the appropriate operations manual.

### **1.2.4. Engine**

Most commonly used engines are Rotax 912, 912S and 914, which provide the aircraft with excellent dynamic and flying performance. The Rotax 912, 912S and 914 are four-stroke four-cylinder engines the type boxer. The cylinder head is liquid cooled and the cylinders are cooled by air.

There is a gearbox reducer on the engine; the engine has two carburetors. Detailed information is provided with the aircraft on operation and maintenance of the engine.

## **ATTENTION!**

**Some engines are not certificated as flying engines. Even though maximum attention is paid during the manufacture of the engine, misfire of the engine can occur at any time. The pilot is responsible for the consequences associated with flying this aircraft.**

**The obligation of the pilot to fly at all times where in the event of an engine failure they are able to glide and land safely to a pre-selected area.**

### **1.2.5. Control movements**

#### **Pilots Feet**

Pushing on the left foot pedal, the airplane turns to the left if on land or in the air, pushing on the right pedal it turns to right on land or in the air.

#### **Joystick control**

Pulling the control stick to the pilot's body will cause the airplane to rise; pushing away the joystick will cause the airplane to descend.

#### **Braking**

The wheels of the main undercarriage have Hydraulic disk brakes, the control is only from the left seat, pushing on the top part of the left pedal will break the left wheel and pushing on the top right pedal will break the right wheel. Applying pressure to the top of both pedals simultaneously will break both wheels.

#### **Flaps**



**T L - 2000 Sting Carbon  
s/n 07 ST 233**



The flaps are controlled by pushing a button and lifting a lever located between the seats, the first position is for take off, the second position is for landing, during normal flight the lever is pushed and locked in the down position.

**Trim**

The trim lever is located in the center panel alongside the throttle, the trim level has three positions; center for take off, forwards for traveling at speed and back for landing when the flaps are deployed.

**Throttle lever**

The Throttle Lever is located between the pilot and passenger in the center consol, forward represents full throttle and backwards returns the engine to idle.

**1.2.6. Basic technical data of the airplane**

Wing span	8.44m
Length	5.93m
Height	2.3m
Wing area	9.8 m <sup>2</sup>
Main wheel-spacing	1.95m
Wheel base	1.65m
Atmospheric pressure in tyres	2.0kPa
Brakes	hydraulic disk brakes
Rebound of main undercarriage	tyres, resilience of the legs of the undercarriage
Rebound of the front wheel	coil spring
Volume of the fuel tank	69 litres
Weight of empty airplane	see 2.2.2.

**1.3. Layout of the airplane**

Dimensioned layout of the TL-2000 Sting

TL - 2000 Sting Carbon  
s/n 07 ST 233

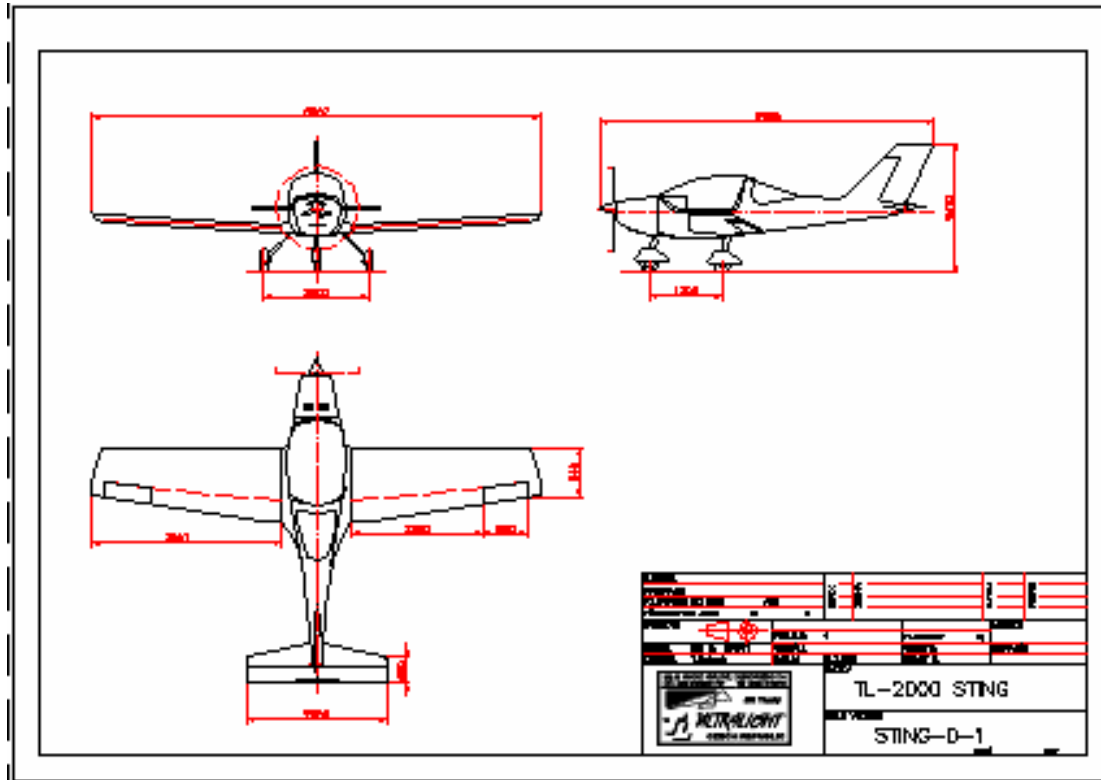

#### 1.4. Detecting the center of gravity position, allowed and measured values

Observance of the center of gravity is vital for the stability and manageability of the airplane. That's why it is necessary for every airplane pilot to know how to diagnose the center gravity position of the airplane for different occupancy.

It is necessary to know the length of the middle aerodynamic range when making the calculation of the center of gravity. Calculated center of gravity must be inside the range given by the producer.

Length of middle aerodynamic substance of the wing      1420mm

Allowed range of the center of gravity in %SAT      22-34 %

When detecting the point of balance and subsequent calculation let the airplane stand in flying position on three weighing machines and proceed following these instructions:

##### 1.4.1. Weighing the airplane for the foreword center of gravity position

- Pilot's seat is occupied with a pilot with the lowest allowed weight
- There cannot be any load on the plane; the fuel tank must be empty
- Measure the weight of the rear wheels; add the left side and the right side together. The total weight on the rear wheels is known as Gp.
- The weight Go is measured under the front wheel.
- Total weight of the airplane Gvzl. is equal to the sum of Gp+Go

**T L - 2000 Sting Carbon  
s/n 07 ST 233**



- Measure the distance of axle of the main undercarriage from the axle of the front wheel  $L_b$  in millimeters
- Measure the distance of leading edge of the wing with a plum bob from the axle of the main undercarriage  $L_a$  in millimeters
- Measure the vertical distance of the point of balance from the axle of main undercarriage  $L_t$  by the formula:  
 $L_t = G_o * L_b / G_v z_l$
- Measure the distance of the point of balance from the leading edge of the wing  $X_t$  by the formula:  $X_t = L_a - L_t$
- Calculate the front center of gravity in percents by the formula  $X\% = X_t / SAT * 100$

**1.4.2. Weighing the airplane for the backmost center of gravity**

Pilot's seat and the seat next to the pilot must be occupied with maximum weight of the crew, also the fuel tank must be full and the useful load must have the maximum weight.

The procedure of measuring and weighing is the same as detecting the front center of gravity

**2. Operating restrictions**

**2.1. Flight operation speeds and position fault of the Air Speed Indicator**

Presented speeds of the flight apply to the maximum take off weight of 450kg and at the conditions of the sea level by the MSA. The speeds are presented in kilometers per hour and Knots.

	<b>Km/h</b>	<b>Knots</b>
Take off speed	75	40
Climb speed	120	65
Travel	120-260	65-140
Accession landing (approach)	120	65
The speed of bearing the surface (landing)	62	34
Maximum speed of horizontal flight	270	145
Never never-exceed speed $V_{ne}$	305	165
Maximum speed at turbulence	220	119
Stalling speed with no flaps	85	45
Stalling speed with flaps 35degrees - 2nd grade flap	70	38
Maximum speed for extending the 1st grade flaps $V_{fe}$	140	76
Maximum speed for extending the 2nd grade flaps $V_{fe}$	120	65

$V_{ne}$  is the never-exceed speed, which the airplane cannot be flown over

$V_{fe}$  is the maximum speed for extending the flaps; there are the same speed restrictions for the flight with extended flaps as for their extension.

**T L - 2000 Sting Carbon**  
s/n 07 ST 233



**2.1.1. Air-speed data and position fault of Pitot tube**

The speed data reported by the air-speed indicator generally do not correspond at all speed ranges to the real aerial speed.

That's why we introduce the reparation of the indicated values for several of the speed ranges. The real speed is at about 6.3% - 8.2% lower than the speed indicated by the board air-speed recorder. At low speed the relative mistake is lower and at higher speed the mistake is increasing.

For safety reasons not extending the maximum allowed speeds we choose the type of lower real calibrated speed than the indicated speed. All speed limits introduced in this guidebook as operating restrictions are initiated as the speeds indicated by the air-speed recorder. There is no need for any recount in the way of functioning of the airplane.

**2.1.2. Reparation table of real and indicated air-velocity in km/h**

Indicated	Actual	Indicated	Actual	Indicated	Actual
60	58	160	148	250	234
70	63	170	157	260	244
80	72	180	167	275	255
90	85	190	176	280	261
100	94	200	185	285	268
120	112	210	194	290	279
130	121	220	204		
140	130	230	214		
150	139	240	224		

**2.2. Weights and loads**

**2.2.1. Maximum and minimum weights**

Maximum taking off weight	450kg
Maximum landing weight	450kg
Maximum weight of the fuel	49kg
Maximum load of one seat	70kg
Maximum weight of load behind the seats	8kg
Maximum weight of the crew	Varies on aircraft empty weight

**2.2.2. Weight of the empty airplane and detected position of the point of balance**

See point 1.4.3.

**2.2.3. Positioning of the load**

See point 2.10.



### 2.3. Engine operating restrictions

#### **ATTENTION!**

**Engines Rotax are not certificated as flying engines and sudden misfire can occur at any time, which can lead to emergency landing. Never fly with this engine at conditions when safe landing without using the engine is possible. There is no life service or safety certificate initiated to this engine. Also it does not correspond to any aerial standards.**

**All risks and the responsibility with using and operating this engine of this airplane are on the side of the user. We inform you, as the user, with the possibility of sudden misfire of the engine.**

Engine restrictions for engines Rotax 912, 912S and 914.

Minimum temperature of air when taking off in Celsius	-25
Maximum temperature of air when taking off	+50
Maximum engine revolutions 1/min	5.800
Maximum steady revolutions 1/min	5.500
Maximum time of running the engine at maximum revolutions	5 min
No-load speed	1,400

This data can slightly differ from the actual conduct of the engine, for more details look at the Instruction manual for using the engine

### 2.3. Propeller operating restrictions

There is a general requirement for protecting the propeller against the effects of rain and sun when not in actual use. Covers for your propeller blades were delivered together with your propeller and please, use them at anytime when your airplane is parked for any time.

Any damage which results in increased vibration is necessary to abort the flight and make repairs according to the manufacturers instructions.

There is a technical description and maintenance checklist for the propeller which you should go through. The supplied propeller was chosen due to match the engine and aircraft you have chosen.

The propeller is subject to regular maintenance by the producer, it will require ongoing maintenance throughout the life of the aircraft.

### 2.4. Fuel and lubricant oil

For engine Rotax 912, 912S and 914 there are many approved fuel types. Details are enclosed in the instruction for maintenance for the engine. It is our experience that we recommend using the petrol Premium Unleaded. Peruse the demands for the fuel prescribed by the producer in detail. In emergency to know what other fuel is possible to use.

There are also conditions prescribed by the producer for the oil used in the engine and these conditions are also enclosed in the instruction for maintenance for the engine. It is our experience that we recommend the oil Castrol R4. There are types of oil with which can reduce the service intervals and shorten them from 100 to 50 flight hours. These details are in the instructions of maintenance for the engine.



#### **2.4.1. Fuel supply**

Total volume of tanks	69litres
Unusable supply	3litres
Minimum amount of fuel when taking off	8 litres

Unusable supply is the amount of fuel remaining in the tanks which cannot be used in general flight.

#### **2.4.2. Consumption of fuel**

The consumption of fuel expressively depends on the type of propeller, engine, the technique of the pilot, total weight of the airplane, height of the flight, flight regime and the consumption is expressively influenced by the meteorological conditions with the consumption being increased with higher temperature. In general, flight with heavier airplane requires higher engine output because for reaching needed rising force it needs to be progressed with bigger angle of incidence, so the aerodynamic resistance is higher.

Aerodynamic resistance is also increasing with second power of the speed of the flight and that's why the consumption of the fuel is increasing with higher speed. The consumption-output of engine curve is enclosed in the instruction for maintenance for the engine. Also used propeller expressively influences the consumption. Positioning the angle of incidence of the propeller blades can be a compromise among many various flight regimes at stationary or adjustable propellers. Using adjustable propeller can the consumption decrease by 10-15%.

The average consumption for steady running flight with the speed of 170kmh using the engine Rotax 912 or 914 and using the on land adjustable 3blade propeller at the weight of the airplane 450kg.

With using the fuel computer, which also evaluates the immediate hour consumption of the fuel, you can, for factual conditions, optimize flight regime and achieve that way another reduction of the consumption.

Remark: In this context it is much more interesting for traveling the consumption of fuel per hour, the consumption of fuel to indicated 100km of flight, so the portion of the fuel in litters and indicated aerial speed in hundreds of kilometers.

Whilst consumption of the fuel for and hour of flight enables us to find out how long you can keep in the air, the consumption of the fuel for 100kilometres tells us what indicated aerial distance the airplane can fly. The flight at minimum consumption for 100km represents the most valuable way of flight for actual trace. You will find out later, that the consumption of 17litres for 1 hour at the speed of 195km/h is more valuable than seemingly low consumption of 12 litters per hour at the speed of 120km/h.

#### **2.5. Restriction of maneuver**

The restriction of the airplane UL in the view of allowed maneuvers is determined by the requirements of the rule UL2 part 2. Which allows for this category only non-acrobatic operating, there are also technical restrictions of the airplane on its own?

Non-acrobatic operation due to UI2, part 1, letter A, point 2 includes any turns needed for normal flying, practicing of drops and sharp turn to 60degrees.

We also stress that the airplane TL 2000 Sting Carbon with its exceptional attributes leads on operating acrobatically, this airplane is not an aerobicic airplane and intentional drops, spins and aerobatics are strictly prohibited.

**T L - 2000 Sting Carbon  
s/n 07 ST 233**



**2.5.1. Allowed turns**

- non-acrobatic operations in sense of definitions proposed at the top by the rule UL2
- sharp turns are not recommended at lower speed than 130km/h
- use maximum 1/3 of full displacement at the speed over 220km/h

**2.5.2. Flight multiples**

Flight multiple expresses the load of the airplane while operating with inertial and aerodynamic power in order to its total allowed maximum weight. Airplane TL 2000 Sting Carbon is certificated for maximum taking off weight of 450kg. Also the rule UL 2 demands the operating multiples

N1	+4.0
N2	+4.0
N3	-1.5
N4	-2.0

N1, N2, N3, N4 ..... operating multiples by the diagram V-a turn envelope

**2.6. The crew**

**2.6.1. Minimum and maximum weight of the crew**

TL 2000 Sting Carbon is two placed and there are three restriction conditions, which must be kept in the view of the weight.

First is the minimum weight of the crew 70kg. This minimum weight ensures the observance of the center of gravity so it's good controllability and the stability at the flight.

If this condition is not fulfilled it is necessary to fasten respective amount of weight to another seat.

Second condition is not to overpass the maximum total weight of the airplane 450kg.

The observance of this condition is for the airplane to have the attributes and be so safe as it has been approved. The weight of the airplane without the crew responds to the sum of its weight with no fuel and the weight of the fuel. There is a label in the cabin on left front side where maximum weight of the crew with various volume of the fuel in the trunk is presented.

Third condition is maximum load of one seat with no more than 110kg.

Remember, usually it is not a problem to take off with over passing the maximum weight but it is exactly the problem of landing.

**ATTENTION**

**Maximum weight of 450 kg can not be overpassed in any case!**

## TL - 2000 Sting Carbon s/n 07 ST 233



### 2.6.2. Pilot's qualification

TL 2000 Sting Carbon is aerodynamically controlled airplane. The rule UL 1 in head 3 determines the requirements for qualification of the pilot for this category of airplane.

The requirements can change by time and that's why getting to know the valid wording of this rule in time when this problem is up to date. In time of pressing this guidebook applies:

- pilot must have the qualification at least of pilot of UL aerodynamic controlled
- if instructor ULLa is on board, the pilot can have the qualification of learner ULLa
- piloting learner ULLa can be on board alone, when he is taken aback by the valid training program in such part, when he is able to operate independent flights
- to be able to have another person on board with no qualification, it is necessary for the pilot to have flown at least 50 flight hours on ULL and from this at least 5 flying hours at the type TL 2000 Sting Carbon

### 2.6.3. Pilot's place on the plane, age of the crew, using the seat belts

The airplane TL 2000 Sting Carbon is equipped with two pilot controls and the ability of seeing the appliances from both seats is well. Assessing the place of pilot is not a technical question but the law question. In this sense from the habit we determine the pilot's seat to the left side.

The age of the pilot is not confined in any way and is derived of the requirements of the minimum age of the pilot or piloting learner by the rule UL3. The upper limit of the age is given by the health capability, so the holding of the valid piloting license.

The age of the other person is not determined by any rule LAA, but in the way of minimum age we can generally consider that the second person of the crew should have the size to be able to use the seat belts.

On basis of this general requirement with reference to the rule UL1, head 3, article 3.3., it is necessary in factual case for the pilot to decide if he will accept factual person on board, taking account on the age, physical and mental ability.

As producers we can not give any recommendation nor any restriction. We lay stress on the crew to be using the seat belts which are fastened.

### 2.7. Maximum flight height

From technical view the airplane is able to rise into such height, when it is permanently able to be rising with the speed of 0.5m/s at the speed of flight 130km/h practical ceiling. Factually this technical ability depends on actual weight of the airplane, conditions of engine, the propeller output, meteorological conditions and etc.

In the way of legislative, the height of the flight is influenced by many restrictions which can change in course of time. Meantime, these restrictions are introduced for example in the rule UL1, head 2, and point 2.7. Make sure you get to know these conditions in its full length. We roughly introduce for orientation, these restrictive conditions:

- with ULLa it is possible to fly only at conditions VFR during the day, and only to the flight level f FL 205, it means 6.250m MSL
- within its borders of the height limit FL 205 it is necessary to respect the conditions laying the flight in single forms of the aerial area flying schedule, radiolink, responder...



**T L - 2000 Sting Carbon  
s/n 07 ST 233**



## 2.8. Meteorologic condition restriction

Operating the airplane is restricted on meteorological conditions and also on constitution of valid rules for the performance of the flight keeping the meteorological minimums and the rules of flights in single forms of the aerial area – see the rule LAA ČR UL1, also technical and flying attributes need to be considered. There are these restrictive conditions:

Maximum outside temperature	+45 degrees of Celsius
Minimum outside temperature	-15 degrees of Celsius
Maximum speed of wind against the direction of taking off	6m/s
Maximum vertical side component of wind	3m/s
Maximum speed of the wind in the direction of taking off	1m/s

Operating restrictions of the airplane in the way of meteorological conditions in cooler weather are determined mostly by the possibility of ice formation. Keep away from flight in conditions which increase the probability of its formation.

## 2.9. Carriage of restricted goods

Transport of load is restricted by the valid rules and also by the technical possibility.

Valid flying rules prohibit the transport of some kinds of loads, for example weapons, explosives, volatile and caustic agents and etc.

In the way of technical possibility the airplane is able for transportation in its cabin only at these conditions:

- maximum weight of the airplane can not be overpassed
- the load can be transferred only if it does not influence controllability of the pilot, the movement and the view of the pilot in any way, also the load must be mounted to the seat
- small sized things can be conveyed in side pockets of padding
- at the put off area in the back under the overlap of the cabin behind the seats there can be conveyed only such things, when the center of gravity will be ensured. At the same time, the load must be kept the way not to terminate the pilot's view and controllability even in worse flying conditions for example flying into the turbulence

## 2.10. Types of airport traffic

Flying rule and the equipment of the airplane terminate the operating with the airplane only for flights under the conditions VFR during the day. Other flights are strictly prohibited.



### 3. Emergency procedures

#### 3.1. Misfire of the engine

The procedure while failure of the engine differs due to the time we have to solve the situation, so the height of the flight where the failure occurs.

##### 3.1.1. Failure of the engine during the flight to the height 200m

- bring the airplane to gliding
- at small height, perform the emergency landing in the direction of the flight because turning at small height above the land and with low speed can give upon the risk of fall into the spin
- at higher height perform other tasks that will increase the safety of emergency landing – which are....
- close the fuel supply to the engine
- fasten your seat belts
- perform the emergency landing to free area with no barriers and if it is possible against the wind

##### 3.1.2. Failure of the engine during the flight above the height 200m

Bigger height will enable you to find out the reason of the engine failure, perform these tasks:

- bring you airplane to gliding
- make sure, the ignition is on
- check the fuel status
- try to launch the engine

If the engine is not able to start up, proceed by the point 3.1.1.

#### 3.2. Fire on board of the plane

In case of fire on board, proceed this way:

- close the fuel supply to the engine
- open to maximum the gas lever of engine for the fastest consumption of the fuel behind the shut-off the fuel

**T L - 2000 Sting Carbon  
s/n 07 ST 233**



- perform the distress call
- after the failure of the engine, turn off the ignition, all electrical appliances and the main switch
- perform the emergency landing

### 3.3. Vibrations

Vibrations can occur due to flight in bad weather flight regime, or due to the technical fault on the airplane.

If unnatural vibrations occur, make sure you are not flying the speed close to the stalling speed or if you are not flying in glide.

The airplane signalize the vibrations in pilotaging the airplane with approaching stalling speed, this is the consequence of beginning breaking of the line of flow. In this case perform the change of flying regime recall the practice of inhibition of the fall.

Vibrations can exhibit by the glide performing and this is the consequence of unsymetric by-passing the aerodynamic clean airplane TL 2000 Sting Carbon. In this case slow down the speed of the glide.

If you quickly exclude some of the sources of increasing vibration written at the top, proceed this way:

- try to find such regime of the engine when the vibrations are as low as possible
- if the vibrations are increasing, perform the emergency landing with turned off engine alternatively perform the safety landing

### 3.4. Undercarriage failure

#### 3.4.1. Main undercarriage failure

Land on the side of not damaged leg, on this side using the ailerons, try to relief the damaged leg as long as possible, in case of the main undercarriage failure.

#### 3.4.2. Front undercarriage failure

In the course of the front undercarriage failure, try to keep the front up as long as possible, if possible do not use brake, because the inertia force actuating on the center of gravity of the airplane is trying while braking to collapse the front of the airplane down. Try to land on a appropriate area and if possible against the wind, to slow down the landing speed against the ground.

### 3.5. Using the saving system

If your airplane is equipped with the saving system, you have received with handed documentations Guidebook for assembling and using the saving system elaborated by the producer. Go through this guidebook in its full length and keep to the procedures which are introduced there.

The handgrip which activates the saving system is placed in the upper part of the back upper lap of the cabin between the seats.

Do not forget to unlock and lock off the saving system before the flight and to lock it after the flight.

**T L - 2000 Sting Carbon  
s/n 07 ST 233**



Generally, the saving system is recommended to use in the case of definite loss of control under the airplane, for example for its destruction. In the case, perform:

- turn off the ignition
- fasten your seat belts
- activate the saving system
- if the airplane is equipped by the radio perform the distress call

When the airplane is dropping steadily, the airplane is in the position wheel down. It is necessary to count with a damage of the airplane when falling down to the ground.

**ATTENTION!**

**The saving system is constructed for the maximum speed of flight 240km/h, so if such situation happens, which responds to using the saving system, arbitrate quickly.**

**Practice the movement of your hand activating the saving system and make sure, there are no barriers in activating-seat belts or clothing. Before the flight, introduce the placing of the starter to the fellow-traveler and let him try on a dustproof system if he is possible to use it.**

## 4. Operating Procedures

### 4.1. Starting up the engine

Tasks which need to have be done especially before first startup of the engine in the flight day, or in the case the engine had cooled down, are written in detail in the guidebook for the maintenance for the engine of your airplane, which was delivered to you with other documents. When starting up the engine, please keep to the device included in that handbook. Here are included some of the principles.

- before starting up the engine, make sure all conditions for its safe starting up are kept UL 1, point 3.8.6
- at a cool engine, turn over the propeller several times in its direction for the oil from the engine to be pushed in the tank
- if the airplane is equipped by adjustable propeller , set it to the smallest angle of incidence

**ATTENTION**

**Always do this task only when the both circles of ignition and the main switch is off**

- open the fuel tap if is closed
- turn on the main switch

**T L - 2000 Sting Carbon  
s/n 07 ST 233**



- turn on both ignition circuits
- at cool engine, pull out the saturator
- set the gas lever for no load, or 10% of the output
- proceed the starter in activity
- be starting up with no interruption for maximum 10sec.

If the engine is not started, let the starter cool down for about 2 minutes and then repeat the starting. Overheated starter loses its output very quickly and the engine is hard to start with it because it does not rev up to the sufficient amount engine revolutions.

#### 4.2. Engine test

The engine test is made when the engine is warmed up with the goal to verify its operating efficiency. The procedure for the warming up the engine and making the test of ignition is again introduced in its full length in the handbook for the engine; keep to the procedures enclosed there.

We initiate only the basic principles:

- let the engine run for about 2 minutes with the revolutions of 2000/minute and continue with its warming up with the revolutions of 2500/min till the oil temperature does not reach 50°Celsius. Check the temperatures and the pressures while warming up and if all operating values have been reached
- do the test of ignition at the revolutions of 4000/min, the drop of the revolutions for each circuit can not be higher than 300 revolutions per minute, the difference of the revolutions can not reach more than 120 revolutions per minute. If you find out that there is no drop of the revolutions, it can mean that interruption of the short circuit cable, which turns off the ignition circuit, has occurred. In this case try to turn off the engine. If the engine would not turn off after turning off both ignition circuits, stop the fuel supply to the engine and let the engine come down. Check the connection of the connectors of the ignition circuit under the engine hood.
- set the revolutions to 5000 per minute for the time of 30 sec
- 3 times smoothly come from the no load to maximum revolutions 5800 per minute
- set the no load
- if you have the adjustable aircrew, re-examine its functioning by reconstructing and set the propeller to small angle of uprising

There can not occur any irregularity nor pendulums of the revolutions while the engine test. No allowed pressure and temperature values can be overpassed. The gas lever should be set slowly and smoothly.

#### 4.3. Important parts made before getting off

Do not underestimate the important parts before the start; make your own system in preceeding them. At the beginning it is convenient to write them down and proceed them by the list.

In the bottom, there is a list, the way you could proceed it from the upper part of the board desk to the bottom part altitude meter, gas pressure indicator to the middle konzola opening and the fuel supply, setting up the propeller, control of the pilotage, setting up the balance, seat belts, to the sides side cabin shut off and to the upper back middle shut off of the cabin, saving system lock off, the check up consists of these activities:

**T L - 2000 Sting Carbon  
s/n 07 ST 233**



- while taxiing, try the function of the brakes and pilotage of the front wheel, maximum speed of taxiing is 4km/h / slow walk /
- set the altitude meter
- check the gas pressure indicator
- check if all required values of the engine are achieved
- check if both ignition circuits are turned on
- check the turning on of the appliances, respectively check the artificial horizon
- check the opening of the supply of the fuel
- check the amount of the fuel / see the minimum amount of fuel at taking off/
- check the setting up of the propeller to the small angle of incidence / when the propeller is adjustable
- check the free movement of the gas lever, pedals, balance and lifting flaps, check the reactions of the controlling agents to the movement of possessing principle, compensate for the slightly heavy on head.
- check the cabin locking off

#### 4.4. Taxiing

Maximum speed of taxiing is 4km/h. There is a very good view from the airplane while taxiing but be careful for barriers in front of the airplane and also on side, especially when you were used to upper wing plane.

Most assembled propeller s has a yellow paint coating on inside ends, which can be interrupting a bit because it makes an annular ring in field of view, but on the other side it supports the safety of taxiing because it defines the working area of the propeller .

Small speed of taxiing can aggravate the ventilation of the cabin, in hot or sunny weather keep your circled side windows opened against the direction of taxiing, the ventilation will expressively get better.

In no case do not taxi with ajar cabin, because while riding on unlevelled ground the cabin hang-up could be damaged

#### 4.5. Taking-off

- lifting flaps should be set to 15 degrees
- release the brakes and smoothly add full gas, you should count with the efficient engine to increase the revolutions of the propeller very quickly and its reaction moment and its oblique blasting action have the effort to change the straight direction to the left at engine Rotax 912, 914
- at the speed of 50km/h, relief slowly the front wheel
- at the speed of 75-85km/h the airplane airbones, keep the straight direction of the flight by declutching of the right leg, hold underfoot and keep till the speed of 130km/h
- come smoothly to rising at the speed of 120km/h

**T L - 2000 Sting Carbon  
s/n 07 ST 233**



- at the height of 50m, close the lifting flaps
- descend the revolutions at latest 5 minutes to at least steady allowed revolutions, if you need to rise more with the airplane rise in the regime of reaching the flight level

**4.5.1. Maximum power of wind at time of taking off**

Maximum wind speed when taking off is enclosed at the point 2.9. Meteorological restrictions

**4.6. Tasks after reaching the flight level**

- trim the regime of the engine to travel regime
- in case of adjustable aircrew, set the propeller to the angle of incidence convenient for the speed of the flight
- outweigh the airplane to horizontal flight
- check the engine values, functioning of the appliances and the regularity of the engine
- evolve the seat belts
- set the required values of heating and ventilation of the cabin

**4.7. Flight at the flight level**

At flight at the flight level it is necessary to count with big sensitivity of controlling agents and the reactions to the pilotage of the airplane change with the speed of the flight, the speed of TL 2000 Sting Carbon has a wide range.

**ATTENTION!**

**Do not perform any sharp turns with speed lower than 130km/h, with speed over 220km/h do not proceed any commotion with the controlling agents and use the maximum of 1/3 of its full displacement.**

Remark: if your cabin is equipped with circle side windows, test when they are turned into the direction of flight the aerodynamic noise in the cabin and the effectiveness of ventilation thank to the force ventilation of the cabin is very good.

**4.8. Descent**

While descending from higher flight levels which lasts longer time we recommend not to descent at no load in order to protect the engine from cooling down, but to descent with slight tension of the engine with the speed about 220km/h.

**4.8.1. Sideslip**

The slip should be performed at the speed between 120 to 130km/h.



#### 4.9. Landing

Set the propeller to small angle of incidence if your propeller is adjustable, in case having to repeat the landing, your engine would have the full disposal of output.

Set the weighing of the airplane slightly heavy on the tale and fasten your seat belts.

After third round turn shift out the flaps at the speed 125-130km/h. After fourth round turn slightly snap and shift the flaps to the 2nd grade. at the speed of 105-110km/h. After shifting out, increase the speed snapping to 115-120km/h, and go to landing with this speed till long wind. The way you are losing the long wind, wind down the speed. Thank to the down-to-earth lifting force you will be bearing relatively slow, on the main undercarriage it will be around 75km/h. With sequent snapping of the gas lever keep the airplane as long as possible only on the main undercarriage. The front wheel will lay on the ground on itself with the speed around 60km/h.

Remark: Shifting especially the 2nd grade flaps at slightly lower speed than is the maximum allowed speed for the 2nd grade speed expressively descent the power, which is necessary for this task.

Consecutive slight speed increase will enable to keep the direction of landing because the rudder is still adequately effective. If you will be coming to landing with too low speed / even though still with the backup against the stalling speed / you will find out, that the effectiveness of the rudder is descending and you will have more work with keeping the direction.

#### 4.10. Tasks after landing

- from the place of landing taxi to the place of parking
- turn off all appliances, respectively horizon
- turn off the main switch
- close the fuel supply to the engine with the fuel tap
- leave the lifting flaps shifted off on 2nd grade this task seems to not be logical because we shift the flaps on the 1st grade before the start, but its purpose is to restrain the possibility of stepping of you own or your fellow-traveller while getting off the plane. The flap is fully shifted off and is expressively bended, the possibility of stepping on it is smaller
- after the propeller stops, lock off the overlap of the cabin, release the seat belts and lift off the cabin. The airplane should stand against the wind when lifting the cabin. The overlap of the cabin has pretty big size and rapid wind directing to the overlap from the back could damage the hung up of the overlap of the cabin
- while parking the airplane, the cabin must be closed so the side or back wind would not apply load in the hung up of the cabin
- **ATTENTION!** Before leaving and locking the cabin lock and lock in the saving system

#### 4.11. Flying in lateral wind

If you will be flying with keeping the prescribed meteorological restrictions, the allowed values do not present any expressive barrier in order to take off nor land.

If you will have to land in stronger lateral wind use the technique of glide against the wind or the flight with lateral bending against the wind.



**T L - 2000 Sting Carbon  
s/n 07 ST 233**



You can also use the possibility of landing at high revolutions than no load revolutions of the engine; its slight force of the propeller expressively decreases the stalling speed.

If the adjustable propeller is assembled, do not forget to set the minimum incidence angle before landing. If the landing runway is wide enough you can shorten the direction of lateral wind landing sideward to the axle of the runway.

#### 4.12. Flight in turbulent atmosphere

We do not overpass the speed 180km/h in turbulent atmosphere, do not fly even too slow under 130km/h. High speed can cause big force by the wind gust, small speed increase the danger of fall of the airplane while flying into the decreasing current of air.

If your propeller is adjustable, set it on a smaller incidence angle and fly with higher revolutions of the engine, you will have the disposal of full output of the engine for case of deeper pancake landing in turbulence. Be ready to quickly add and detract the gas.

The flight in turbulence is stressing for the pilot and also for the airplane. If it is possible, you can mount to higher flight level, where most turbulence often disappears.

#### 4.13. Standing up to the plane

When standing up to the plane, use the footrest placed on the side of the airplane.

Stand up to the airplane one after another, care about standing persons not to stand up at one time. If both persons would weigh with their weight the footrest at one time, re -weighing to the tale could occur. Step on the wing only in the place where antislip strips are marked in.

### 5. Performance

#### 5.1. Assumptions for performance calculations

All calculations are based on MSA at mean sea level, aircraft in steady flight and aircraft at the maximum permitted take off weight of 450kg.

#### 5.2. Speeds

Stalling speed of the airplane in the landing configuration $V_{so}$	72km/h
Maximum never-exceed speed $V_{ne}$	305km/h
Maximum speed of horizontal flight with maximum steady output of the engine $V_h$	270km/h

These figures have been calculated at the maximum aircraft weight of 450kg and will vary dependant on such factors as weight of the aircraft and altitude above mean sea level.

#### 5.3. Rate of climbs and height loss from the beginning of stalling

Maximum rates of climb are determined at a maximum all up weight of 450kg with maximum engine thrust and are adjusted to mean sea level. With increasing altitude the rate of climb progressively decreases.

**T L - 2000 Sting Carbon  
s/n 07 ST 233**



Rate of climb for the engine Rotax 912	5.0m/s
Rate of climb for the engine Rotax 912S	6.0m/s

The minimum height loss from the point of stall to the point of regaining normal flight is 15m. During a 30 degree banking turn, this height loss increases to between 20 and 25m.

#### 5.4. Ceiling

The practical ceiling is defined as the maximum altitude capable whilst still maintaining a climb rate of at least 0.5m/sec.

The aircraft's maximum ceiling at a maximum permitted take-off weight of 450kg and a Rotax 912 or 912S engine is 6500m.

#### 5.5. Gliding range

The following figures are for an aircraft fitted with a two blade wooden propeller at a glide speed of 130km/hr.

Gliding ratio with engine idling	16.8:1
Gliding ratio with turned off engine	15.2:1

When using a three blade propeller the glide ration for an aircraft with engine idling will increase due to the addition thrust provided by the engine. Similarly, for a three blade propeller the glide ration will decrease when the engine is switched off due to the increased drag.

#### 5.6. Length of start

Takeoff length has been determined within the following constraints:

- Maximum All Up Weight of 450 kg
- Nil wind
- Dry, straight and short cut grassy landing strip
- Nil gradients
- 1st Stage of flap

The following figures are provided for Rotax engines with the first figure denoting the first point at which the aircraft is airborne and the second figure denoting the distance required to clear a 15m obstacle.

Engine	Airborne	Dist to clear 15m
912	90m	270m
912S	75m	220m

#### 5.7. Landing length

Landing length has been determined within the following constraints:





## 6. Maintenance and operating the plane

When parking the aircraft it is necessary to:

- Close fuel valve
- Turn of all electrical appliances
- Ensure all switches are in the Off position
- Replace safety pins in the ballistic chute rescue system
- Lock the canopy
- Place chocks around the main undercarriage
- If leaving the plane for an extended period, tie down in accordance with item 6.2
- Place covers on the propeller
- Cover the pitot tube
- Cover the canopy

### 6.2. Anchorage of the airplane

Anchorage points are provided on the underside of each wing. These should be used to secure the plane in windy conditions. The nose wheel fork may also be utilized if required.

If required, the rear fuselage may be anchored by the use of a wide strap placed around the body. It is recommended that a soft, clean pad be placed under the strap to prevent slippage and also prevent scratching and damage to the fuselage.

### 6.3. Manipulation with the plane

The aircraft is provided with a tow bar which secures to the stub axle of the nose wheel. Due to the low weight of the aircraft, one person can easily manipulate the aircraft using this bar.

When the tow bar is unavailable, the aircraft may be handled by:

- Pushing on the leading edge of the wings within a distance of 2m from the fuselage;
- Placing the arm over the rear of the fuselage, pressing down to lift the nose wheel from the ground, and turning the aircraft as necessary; and
- Pulling on the propeller from an area as close to the hub as possible.

### 6.4. Assembly and disassembly of the plane

Assembly and disassembly of the plane should be done only by trained persons. Assembly and disassembly should be performed only when necessary as excessive wear and loosening of fixtures and connections could result with repeated assembly and disassembly.



#### 6.4.1. Disassembly of the plane

The following routine should be performed by two persons to disassemble the aircraft:

- remove both seats
- screw out the aileron connecting struts
- screw out the locking bolt in the spar pin
- remove the spar pin by turning the pin 180 degrees
- lift off the sitting parts of the seat
- screw out the aileron connecting strut
- screw out the union bolt of the hinge of the spar
- release the eccentric hinge of the spar turning the lever of the hinge for about 180 degrees
- take out the hinge of the spar of the center-section
- shift out the wings of the center-section
- dismantle the ball joint of the draw rod of the balance area drive
- release all insurance sheet metals of the disassembly hinge of the elevator
- compress the disassembly hinge of the elevator to our body through the cut out area and shift out the elevator to the back

#### 6.4.2. Assembly of the plane

The assembly of the plane should be performed by to persons in reversed order than the disassembly of the plane.

### ATTENTION!

**All self-stop hunts with the nylon rings can be used only once. All metal can be used at maximum 3times after the compression of its cut out from the tongs.**

After assembly the following tasks must be performed:

- Check the entire airframe for geometry, damage or abnormal stress indications.
- Check for the full and free movement of all control surfaces and the correct operation of the flaps and elevator trim tab.
- Manually wobble the wings from the outboard edge and listen and watch for indications of abnormal noise, cracking or deformations.
- Perform a full pre-flight inspection.



## 6.5. Washing and cleaning the plane

### **Attention!**

**Cover the Pitot tube while washing the airplane to protect it from water ingestion.**

For maximum performance, keep the plane clean and polished. Wash only with non-abrasive agents such as car washing detergents. Use only soft rags or chamois on the canopy and ensure that the material used is clean and free from dust so as to avoid scratching the canopy.

Be sure to pay particular attention to wheel covers and suction openings on the engine cowl as these are likely to gather grass, dirt and other items.

Use lukewarm water for best results when washing the airplane. Wash the plane in sections and then dry to avoid buildup of mineral deposits from the water. To remove stubborn deposits such as flies or bugs, use similar agents to those used in car detailing applications.

Once a month or as required, polish the surface of the aircraft and canopy to preserve the finish. Car polish and glass or plastic preservation liquids may be used.

## 6.6. Before flight inspection

The pre-flight inspection starts on the left side of the cabin and proceeds clockwise. Perform the following inspections prior to each flight:

### **Canopy**

- check the cleanness
- check for damage to seals
- check for correct seating
- check locking mechanism for correct function

### **Cockpit**

- Ensure all switches in Off position
- Ensure all controls are free

### **Engine**

- remove upper cowl
- check engine mounts for security and wear
- check all cables for security and any damage
- check security of the accumulator
- check the security of the fuel hoses, air filter and exhaust

**T L - 2000 Sting Carbon  
s/n 07 ST 233**



- check the exhaust springs for security and integrity
- check the security of oil cooler
- check the radiator for security and any leaks
- check the security of the spark plugs and cables
- check in oil level and refill if necessary - the oil level must be between the min and max marks
- check coolant and refill if necessary - the coolant liquid level should be at 2/3 of the maximum volume of the tank when the engine is cool.
- check brake liquid level and refill if necessary
- check battery levels
- check for cleanliness of the fuel filter and change if necessary
- replace the engine cowl and check security

**Important**

Watch for possible rubbed places on pipes, especially at points where they are secured, or at places where they are connected to metallic parts of the engine.

If you experience problems with the connection of the carburetor to the engine via the rubber tubing, it may be necessary to modify the attachment in accordance with the engine maintenance handbook.

If the pipe is rubbed conically, you should assume that small parts of the rubber could have entered the carburetor. Entrust its cleaning to an authorized person.

**Propeller**

- check security
- check for possible damage
- check spinner for security
- if the propeller is electronically adjustable, check that it operates correctly

**Nose wheel**

- check the symmetry
- check for malformation
- check for alignment and spacing
- check wheel cover for security
- check the security of the nut of the nose wheel securing screw – paint mark should indicate no movement
- check security of front wheel axle nuts

**T L - 2000 Sting Carbon  
s/n 07 ST 233**



**Nose Wheel Tyre**

- check the tyre tread for wear
- check for cracks, bulges
- check tyre pressure is 2.0KPa.

**Right wing**

- check the peito and static connection in the center of the plane by lifting up the seats in the cabin
- check flaps hinges and cotter pins
- check flaps for security
- check aileron hinges and cotter pins
- check free movement of ailerons

**Right Undercarriage**

- check symmetry of undercarriage
- check wheel cover for damage
- check brakes
- check for malformation
- check for alignment and spacing
- check axle securing nuts

**Right Wheel Tyre**

- check the tyre tread for wear
- check for cracks, bulges
- check tyre pressure is 2.0KPa.

**Right side of the body**

- check the fuel cap
- check for damage to the aircraft skin

**Tail area**

- check for free movement of elevator
- check correct operation of trim tab
- check for surface damage



**T L - 2000 Sting Carbon  
s/n 07 ST 233**



- check rudder hinges
- check the position of the elevator and the rudder (geometry)
- check for free-play in elevator and rudder
- check all rivets for security and damage
- check connection of control lines
- check tail cone for security
- check all nuts and bolts for security

**Left side of the body**

- check security of inspection plate
- as for the right side

**Left wing**

- the same as the right wing

**Left Undercarriage**

- the same as the right undercarriage

**Left Wheel Tyre**

- as for right wheel tyre

**Interior of the cabin**

- check the cleanliness
- check full and free movement of controls
- check correct functioning of controls
- check all control linkages
- check all electrical appliances
- check the uniformity of position of the flaps at all positions on both wings.
- check all screws, nuts and bolts for security
- check all connections, hinges, springs

6.7 Filling the fuel

**ATTENTION!**

**T L - 2000 Sting Carbon  
s/n 07 ST 233**



**Due to the construction of the airframe, static electricity buildup is possible. Ensure that all fuelling hoses are adequately grounded to reduce the possibility of sparking and fuel ignition.**

The following procedure should be followed when fuelling the aircraft:

- Ensure there are no personnel in the aircraft
- Ensure there are no naked flames within 50m
- Ensure that no one is smoking within the fuelling area
- Ensure that a fire extinguisher is available if needed
- Ensure the grounding cable is attached
- Ensure the grounding cable on the right undercarriage leg is touching the ground
- Ensure that all containers and funnels are marked fuel safe
- Ensure that all switches are in the Off position
- Close the fuel valve
- Unlock and open the fuel cap
- Fill the plane slowly to avoid spillage
- While filling, do not lean on the aircraft as damage to the aircraft skin may result
- Do not place fuel containers on the wing as damage to the wing may result
- After filling, ensure the cap is replaced securely and locked in place
- Wipe away any fuel spillage

## 7. Service life of airplane and periodic maintenance

Regular and careful inspections and maintenance are the principles of reliable and safe operation of the airplane. Maintenance routines and repairs should be documented in the aircraft logs.

### 7.1. Service life of the plane and its parts

There are three major components which determine the life of the aircraft:

- Airframe
- Engine
- Propeller

**T L - 2000 Sting Carbon  
s/n 07 ST 233**



The service life of the airframe will depend on the stresses experienced during its lifetime. Avoid high stress maneuvers and rough turbulence where possible. Do not disassemble the aircraft needlessly and only anchor the aircraft in accordance with the manufacturer's instructions.

Whenever possible, hangar the aircraft to avoid damage by the sun, dust and wind. If hangarage is not available, cover the aircraft if possible. Regular polishing with high quality car polishes will aide in maintaining the airframe.

The manufacturer gives 100 flying hours warranty. The servis life of the airframe is not limited.

The propeller should undergo regular inspections as set out by the manufacturer. To prolong the life of the propeller, avoid long grass and stone areas which may damage the leading edge.

There is no specified service life of the engine. The engine is subject to review by the manufacturer after every 1200 hours.

## 7.2. Daily maintenance

Upon receipt of your new aircraft, you should conduct a thorough inspection including checking the security of all engine components and the state of the fuel filter. Check for any components or control linkages and fittings that may have come loose in transit.

### **ATTENTION!**

**Change the fuel filter preventively after the first ten hours of operation.**

We can not exclude the possibility of getting dust or other dirt into the fuel tank during final construction and this debris may be dislodged during initial flights. It is important to check the fuel filter for contamination frequently during the first 10 hours of flight.

It is preferred to use filters with a clear housing rather than an opaque housing as these will more clearly display any contamination in the fuel lines. The fuel filter should be checked during every pre-flight. Further engine and airframe checks are detailed in item 6.6.

#### **7.2.1. Lubricant plan and lubricant types**

Use only engine lubricants which have been prescribed by the engine manufacturer and detailed in the engine maintenance handbook. The lubricant used by the aircraft manufacturer will be detailed in the aircraft delivery report and also marked on a label located on the upper engine cowl.

Engine oil should be replaced after every 100 hours of operation.

In other areas requiring lubrication, any oil or grease designed for that particular type of lubrication may be used. Use a syringe with a large diameter needle to lubricate hard to reach areas. In most places, the lubricant serves to prolong the life of components so the following schedule should be followed:

Place	Type of lubricant	Frequency
Front undercarriage leg	grease	once a year
Aileron hinges	transmission oil	every 50 hours
Upper and bottom rudder hinges	transmission oil	every 50 hours

**T L - 2000 Sting Carbon  
s/n 07 ST 233**



Elevator hinges	transmission oil	every 50 hours
Control linkages	transmission oil	every 50 hours
Aileron hinges	transmission oil	every 50 hours
Flap hinges	transmission oil	every 50 hours

Most areas can be reached easily however the control linkages require removal of the seats and rear linkages require removal of the rear inspection panel on the main fuselage in front of the rear stabilizer.

### **7.2.2. Ground Handling**

The aircraft is supplied with a handle for manual ground handling of the aircraft. During normal maintenance procedures, no special chocks or supports are required.

### **7.2.3. Removal of the front wheel**

The removal of the front wheel requires two persons. Prepare the bracket under the support points by the point 7.7., ensuring wedge and self protecting nut M14.

While disassembling proceed this way:

- ensure the wheels of the main undercarriage by the wedges from both sides
- take off the upper and low part of the engine cover
- slacken one of the nuts from the front wheel axle and screw it out
- compressing the upper part of the body in place in front of the tale areas and relief the front wheel, shore up the engine bed in the place by the point 7.8.
- extrude the axle from the relief wheel and take the wheel out

While assembling the front wheel, proceed it reversed way. The old nut should be replaced by new one, also perform the signature of the nut position on the hinge with color.

### **7.2.4. Wheel disassembly of main undercarriage**

The disassembly demands the cooperation of two persons, for assembly prepare the bracket, ensuring wedges and self protecting nut M14.

- ensure the second wheel of the main undercarriage by the wedges from both sides
- raise the airplane on the wing at the side of the disassembling wheel and support it under the wing by the point 7.8.

**T L - 2000 Sting Carbon  
s/n 07 ST 233**



- release the inside nut of the hinge of the wheel and lift up the hinge of the wheel from the undercarriage leg without lifting up the hinge with the wheel, the back inside screw of the wheel cover would be able to be screwed out poorly
- disassemble the wheel cover hanged up with 3 screws M6
- screw out 2 screws with the spring and with the inside hexagonal with which is fastened the brake valve on the braking shield
- lift up the inside braking plate to the direction down and take it out of the brake valve
- take out the brake valve from the braking disk by compressing to back
- screw out the inside nut of the hinge of the wheel
- take out the wheel from the axle

Reverse the above sequence to reassemble the main undercarriage.

**7.2.5. Mending the tyre**

Do not use liquid tyre repairs that require 30 minutes of rotation of the tyre to be effective as this period of rotation cannot be guaranteed. These agents may also settle in the tyre unevenly and cause vibration in the aircraft immediately after take-off. It is recommended that tyres are replaced, rather than repaired, in the event of puncture.

**7.2.6. Electrical system voltage**

The aircraft is fitted with a 12V negative earth electrical system. Some of the electrical items, such as the radio, have their own inline fuse however there are no master circuit breakers or fuses installed. Each of the main switches acts as a fuse.

During normal operation, if the voltage drops when switching using appliances, such as transmitting on the radio or altering the pitch of the propeller, check the battery for corrosion, correct connection and electrolyte level. If the fault remains, check the entire electrical system or refer the problem to an authorized service centre.

**7.2.7. Tolerance and setting up values**

Distance of spark plug electrodes	0.7mm
Tyre inflation pressure	2.0hPa

**7.2.8. Supporting and subordinate construction**

Wings, tail areas and the main fuselage are considered as the supporting constructions. Non-supporting constructions include the upper and the lower engine cowl, covers of the undercarriage wheels and the aerodynamic cover of the front undercarriage leg.

No modifications or repairs are to be undertaken on the supporting constructions without prior consultation with the aircraft manufacturer.



### 7.2.9. Assembly of the aircraft

No special tools are required for the assembly/disassembly of the aircraft. Standard workshop tools will suffice.

### 7.2.10. Special tools

The aircraft is supplied with a spark plug spanner. No other special tools are required for servicing and maintenance of the aircraft.

### 7.2.11. Materials for minor repair to the aircraft surface repairs

Due to the type of construction, only minor repairs may be made to the surface of the aircraft. For these repairs, use two component mastic. Clean and degrease the damaged surface with petrol and cement it with the mastic prepared according to the directions for its use. Once the repair has hardened, rub it back and paint as necessary.

### 7.2.12 Changing the fuel filter in the engine area

The fuel filter should be checked regularly to ensure that it is not blocked and replaced as necessary. Due to possible dust and dirt remaining in the fuel tank after construction, the first change of the filter should occur after a maximum of 12 hours operation and then at least every 50 hours.

## ATTENTION!

**Perform the filter change on a cool engine only**

The process for changing the fuel filter is:

- Close fuel valve
- Remove upper engine cowl
- Release buckles on pipes on both sides of fuel filter (leave buckles on the pipes)
- Remove the filter while turning the pipes, taking care not to spill too much fuel
- Replace the filter
- Replace the pipes on the new filter ensuring that the filter is fully inserted
- Replace buckles on the pipes and tighten
- Lockwire buckles
- Open fuel valve
- Operate engine for 5 minutes with no load
- Ensure filter is full of fuel and engine operates normally
- Replace upper engine cowl



Remark: Close the fuel valve when changing the fuel filter. Failure to do so will allow excess fuel in the fuel line to drain back to the tank resulting in a long priming period before the engine may be restarted.

### **ATTENTION!**

**After changing the fuel filter, pay extra attention to the engine run-up before flight to make sure the fuel system is functioning correctly.**

#### **7.2.13 Maintenance of SR 2000 Woodcomp Propeller**

A visual inspection of the propeller blades, leading edges, hub and spinner is to be performed every 10 hours. During this inspection, clean the propeller with non abrasive, non-corrosive cleaning agents.

#### 7.3. Warranty Service

A warranty service is conducted after 25 hours of service and is performed by an authorized service centre. A full review of the aircraft is undertaken and a minor service of the engine is performed including change of oil and oil filter.

#### 7.4. Periodical revision after every 50hours

Every 45-55 hours the following tasks are to be performed by the owner or approved maintenance person:

- Full pre-flight inspection
- Inspect all fixtures, rivets, nuts and bolts for security
- Inspection of internal fuselage
- Inspection of fuel system for leaks, security of fittings and cleanliness of filter
- Inspection of engine mounts and fixtures
- Inspection of brake system and operation
- Engine maintenance in accordance with manufactures directions

#### 7.5. Periodical revision after every 100hours

Every 95-100 hours or 12 months from the last inspection the following tasks are to be performed by the owner or approved maintenance person:

- 50 hourly inspection and maintenance
- inspect airframe and repair as necessary
- inspect and polish canopy and repair if necessary
- inspect flight controls and cables for wear and damage

**T L - 2000 Sting Carbon  
s/n 07 ST 233**



- perform engine maintenance in accordance with manufacturer's handbook
- inspection and service propeller in accordance with manufacturers instructions
- flight test

#### 7.6. Periodical revision after every 200hours

As per the 100 hour inspection, but also the ignition plugs are changed.

#### 7.7. Inspection after every 300hours

This revision is made after every 295-305 flight hours or after three years of operating. The diagnostics of all stressed parts of the construction is made and also its detailed range is prescribed by the internal rule of the producer by the detected state. We introduce here basic tasks for your information:

- revision after 100 hours
- taking off the propeller and the engine
- revision of the construction
- revision of the interior of the body and the cabin
- the outer revision of the whole airframe
- pilotage revision
- replacement of intended parts
- flight test by the probationary pilot

### **ATTENTION!**

**This inspection is made only by the service center of the producer.**

#### 7.8. Jacking points on the plane

The lower engine mounting bracket has been designed with jacking points at the point at which the mount meets the fuselage firewall. This enables the lifting of the nose wheel when the lower cowl is removed.

When jacking the plane utilizing these points, ensure that the wheels of the main undercarriage are secured so as to prevent the aircraft from toppling off the jack.

The main fuselage may be lifted by placing supports under the main wings 190cm out from the fuselage. The supports must provide even distribution of load over an area at least 100mm wide and 1000mm long. A 20mm thick felt cover will allow the even distribution of load across the support and also provide protection for the undersurface of the wing.

#### 7.9. List of labels and their placing

The following labels may be found on the aircraft:



**T L - 2000 Sting Carbon  
s/n 07 ST 233**



- Airframe manufacturer details, including the airframe serial number, are located on the inner left side of the fuselage behind the pilot's seat.
- Aircraft manufacturer's details are located on the partition behind the passenger seat.
- Maximum all up weight details and fuel capacity details are located in the cockpit on the left side.
- Engine oil details are located on the upper cover of the engine adjacent the oil filler cap.

## 8. Airplane repairs

### 8.1. Repairs of nuts and bolts

Damaged or corroded nuts and bolts should be replaced as soon as possible. Where the thread has been damaged, both the nut and bolt must be replaced. Replacements should be of the same type and quality.

Nylon lock nuts may only be used once and therefore should be replaced if the nut is removed for any reason. Full metal nuts may be used up to three times before replacement and must be locked in place with locking wire or other method.

### 8.2. Repairs of rivet joints

If a rivet joint is damaged in any way, the rivet must be removed and replaced. After removal, a close inspection must be done to ensure that no damage to the riveted surfaces has occurred. In the event that no further damage is evident, the rivet may be replaced with the same type and quality. Where further damage has occurred to the riveted surfaces, the manufacturer should be consulted to determine the appropriate repair methods.

### 8.3. Control system repairs

Control columns, connection points, control lines, bearings and other parts can not be repaired and should immediately be replaced if damaged or malformed in any way.

Individual parts can be replaced only by original parts sourced from the manufacturer.

All repairs to the aircraft control systems should be completed by an authorized service person and the aircraft must be test flown by a suitably qualified pilot prior to returning to flight status.

### 8.4. Airframe repair

Minor damage to the surface finish of the aircraft should be cemented, rubbed back and painted. Perforation of the aircraft skin in non-structural areas such as the lower cowl, wheel covers and front undercarriage cover may be repaired with one or two layers of laminate cemented into position, rubbed back and painted. Cementing should be done with component car mastic in accordance with the directions for its use.

Other damage to structural surfaces should be referred to the airframe manufacturer for the correct method of repair or replacement.



#### 8.5. Fuel system repairs

All fuel system malfunctions, damage or leaks must be repaired immediately. Minor repairs such as tightening of fuel line sleeves, cleaning of filters, etc may be repaired by the owner. All other major repairs must be referred to an authorized service representative.

#### 8.6. Engine repairs

All engine repairs must be performed by an authorized service centre. Engine faults can be identified by abnormal engine noise, increased vibrations, fluctuations in engine RPM, engine misfires, reduced performance, abnormal smells, difficulty in starting, etc.

#### 8.7. Electronic and appliance repairs

In case of electrical fault, the owner may make simple repairs such as charging the battery, cleaning the contacts and repair or replacement of broken wires and cables. Other repairs of the electrical system and other appliances may be performed only by an authorized service representative.

### **ATTENTION!**

**All reparations must be written down in the flight book. All damages which have influence on the stability of the construction and the flight characters are necessary to be announced to the producer, which will determine the reparation.**

#### 8.8. Inspection of electrical system

All cable connections must be checked for security, wear, abnormal damage and corrosion. Replace any corroded or damaged cables prior to flight.

Indications of wear or damage may include, but are not limited to, corrosive buildup on terminals, melted, loose or broken insulation or disconnected or exposed wires.

Ensure that spark plug cables are secured correctly and not loose on the plug. Release of the plug connector can be the reason for burnt or melted cables and improper operation of the engine.

Check the level of electrolyte in the battery in all chambers and fill with distilled water if necessary. Recharge the battery regularly if the engine is not operated for extended periods.

#### 9. Engine Rotax 912, 912S and 914 maintenance

The primary reference for maintenance of the Rotax engine should be the Rotax engine owner's handbook provided with your plane.

The engine should be kept clean and inspected regularly for oil leaks or other indications of engine problems. All major servicing should be carried out by an authorized person.

This manual only includes the basic tasks for general operation and maintenance of the Rotax engine.

**T L - 2000 Sting Carbon  
s/n 07 ST 233**



### 9.1. Oil refill

The oil filter should be replaced whenever the oil is changed. This should be done after the first 25 hours of operation and then every 100 hours or 12 months. Both engine oil and gearbox oil should be changed at these periods.

The amount of the oil required for a complete refill is 3 liters.

The handbook for maintenance of Rotax 912/914 engines requires that after each exchange of the oil the old filter is opened and inspected for any foreign material, such as metallic filaments, which may indicate abnormal engine wear and possibility of the engine failure. We recommend having this work done by an expert technician

### 9.2. Spark plugs

Spark plugs should be inspected and cleaned every 100 hours or when the engine becomes difficult to start. Electrode spacing should be 0.7mm or as stated in the engine manufacturer's handbook.

Fouled or discolored plugs may indicate other engine anomalies such as loose valves, incorrect mixture setting, fouled air filter or incorrect engine operating temperatures. The correct spark plug color should be a light brown. Refer to the engine manufacturer's handbook for further information.

Spark plugs should be replaced every 200 hours or when damage or wear is evident during normal inspections.

When reinserting spark plugs, Rotax recommends covering the screw with a heat conductive paste to improve the transfer of heat between the body of the plug and the cylinder head.

### 9.3. Refrigerating liquid

Use only coolant liquids containing anti-corrosion additives and marked suitable for use with aluminum based alloy engines. Do not use coolant liquids in higher concentrations than those prescribed by the manufacturer as damage to the coolant system may result.

Coolant liquid level should be checked regularly and generally replaced at the start of winter and summer.

## **ATTENTION!**

**Do not open the coolant tank when it is hot as severe burns may result.**

To replace coolant liquid, remove the cap on the coolant liquid tank, release the hose clamp on the water pump and remove the rubber pipe to drain the liquid. After draining the liquid, immediately replace the pipe on the water pump.

When replacing the coolant liquid, the tamping underneath the hose clamp should also be replaced to reduce damage to the pipe. Ensure that the hose clamp is tightened to 10Nm.

Addition of coolant should be done directly into the top cap of the coolant liquid tank.

### 9.4. Service life of the plane, revisions and inspection of the engine

Use the liquid with anti corrosive ingredients prescribed for the block of engines from aluminum base alloys. Do not use the refrigerating liquid in bigger concentration; it can be detrimental for individual parts of the refrigerating system.

The refrigerating liquid density should be checked before the beginning of winter. Fill the refrigerating liquid to the tank.



### **ATTENTION!**

**Do not open the tap of the refrigerating liquid tank in hot state. You can get burnt easily.**

While letting out the refrigerating liquid it is necessary to open the tap of the tank and screw out the low tightening screw / with the impermeable ring / of the water pump. Then it is necessary to release the low pipe of the cooler of the refrigerating liquid / which is located lower than the engine to let the old refrigerating liquid leak out, after letting it out, put the pipe back on the cooler and tighten the buckle carefully. While exchanging the refrigerating liquid it is also necessary to exchange the tamping under the low tightening ring of the water pump. This screw is tightened by the moment of 10Nm.

#### 9.4. Service life, revision and engine revisions

Engine maintenance periods have been set at 25, 50, 100 and 200 hours with an acceptable tolerance of  $\pm 10$  hours. This tolerance is not cumulative. The 100 hourly inspection and maintenance schedule should be carried out annually irrespective of hours flown.

The 25 hourly inspection and maintenance schedule should be carried out on new engines and after a general overhaul.

Further information on engine maintenance and inspections is available in the engine handbook supplied by the engine manufacturer. This manual is intended for use by qualified service personnel only and all maintenance is assumed to be undertaken by such persons.

The oil and oil filter should be replaced during the 25 hourly inspection and maintenance routine.

The service of the engine after 50 hours is not recommended by the producer, with the exception being for engines run on AVGAS, where it is also necessary to exchange the oil after 50 hours of operation.

### **ATTENTION!**

**After every exchange of the oil filter, it is recommended that a thorough internal inspection of the old filter be carried out to ensure that it does not contain metallic filaments or other foreign matter. The appearance of these substances within the filter may be an indication of abnormal engine wear or engine damage.**

Some maintenance tasks to be undertaken at the 100 and 200 hourly maintenance periods may only be undertaken by an authorized technician. We recommend that this servicing be undertaken by the engine manufacturer or his nominated representative.

### **ATTENTION!**

**Engine warranty is subject to the strict adherence to maintenance schedules and operating procedures as prescribed in the engine operations manual and aircraft flight manual. It is recommended that, during the warranty period, all maintenance on the engine be undertaken by an authorized service representative or suitably qualified person.**

**T L - 2000 Sting Carbon  
s/n 07 ST 233**



9.5. Service life of rubber parts of engine

All rubber components around the engine, including engine mounts, etc. should be replaced every five years. This should be done irrespective of visual inspection results and replacement should be carried out by an authorized maintenance person.